

User Manual

On-Line UPS Three phase

40 kVA / 60 kVA / 80 kVA / 120 kVA

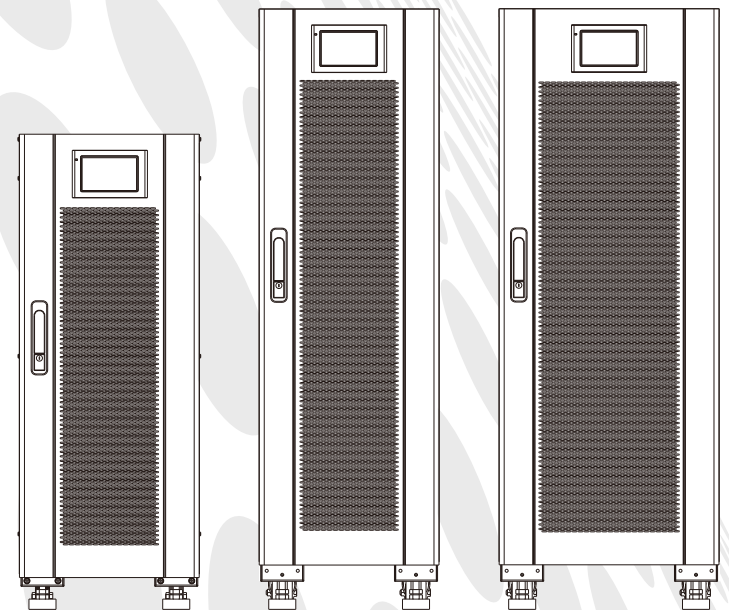

Table of Contents

1 Safety and General Information.....	3
1.1 General Information.....	3
1.2 UPS Safety	3
1.3 Battery Safety.....	3
1.4 Description of Symbols.....	4
2 Product Overview	5
2.1 Working Principle.....	5
2.1.1 Schematic Diagram.....	5
2.1.2 Operating Mode	5
2.2 System Structure	7
2.2.1 40 kVA / 60 kVA UPS System Structure	7
2.2.2 80 kVA / 120 kVA UPS System Structure	8
2.3 Optional Accessories	9
3 Installation.....	10
3.1 Installation Preparations.....	10
3.1.1 Site Preparations.....	10
3.1.2 Installation Tools.....	11
3.1.3 Preparation of Power Cables	11
3.1.4 Unpacking.....	13
3.2 Installation of Single UPS System	14
3.2.1 UPS Installation	14
3.2.2 Install Tightening Components	14
3.2.3 Install Batteries	15
3.2.4 Connect Power Cables.....	15
3.2.5 Connect Grounding Cable	18
3.2.6 Communication Signal Interface.....	18
3.3 Installation of Parallel UPS System	22
3.3.1 Connect Power Cables.....	22
3.3.2 Connect Control Cables	23
3.4 Installation Inspection.....	24
4 UPS Display Interface	25
4.1 Monitoring Display Unit	25
4.1.1 Panel Appearance	25
4.1.2 LCD and Indicator Lights.....	25
4.2 Display Interface.....	25
4.2.1 Overview.....	25
4.2.2 Home Page.....	26
4.2.3 System	27

4.2.4 Alarm	32
4.2.5 Control.....	33
4.2.6 Settings.....	36
5 Operation.....	47
5.1 Operation of Single UPS System	47
5.1.1 Turn On the UPS.....	47
5.1.2 Turn Off the UPS	48
5.1.3 Battery Cold Start.....	49
5.1.4 Transfer to Bypass Operation by Manual	50
5.1.5 Transfer to Maintenance Bypass	50
5.1.6 Power Supply Restored from Maintenance Bypass to Inverter.....	50
5.1.7 Emergency Power Off (EPO).....	51
5.1.8 EPO Recovery	51
5.1.9 Firmware Upgrade	51
5.2 Operation of Parallel UPS System	52
5.2.1 Start Up Parallel System	52
5.2.2 Shut Down Parallel System.....	54
5.2.3 EPO	54
5.2.4 Single UPS Unit Exit the Parallel System	54
5.2.5 Add a Single UPS to the Parallel System	54
6 Maintenance	55
6.1 UPS Maintenance.....	55
6.1.1 Monthly Maintenance	55
6.1.2 Quarterly Maintenance	55
6.1.3 Annual Maintenance.....	55
6.2 Battery Maintenance	56
7 Troubleshooting	57
8 Technical Parameters	58
Appendix 1 Display Menu.....	60
Appendix 2 Alarm List.....	64
Appendix 3 Abbreviations.....	72

1 Safety and General Information

1.1 General Information

- Please read the "safety precautions" carefully before installing and using this product to ensure correct and safe installation and use. Please keep this manual properly.
- UPS must be installed, tested and maintained by an engineer authorized by the manufacturer or its agent, otherwise it is possible to endanger personal safety and cause equipment failure. The damage to UPS caused thereon is excluded from the warranty.
- Under no circumstances shall equipment structure or components be dismantled or changed without the manufacturer's permission, otherwise the damage to UPS caused thereby shall not be covered by the warranty.
- Local regulations and laws shall be followed when using equipment. The safety precautions in the manual only supplement the local safety regulations.
- Due to product version upgrade or other reasons, the content of this document will be updated from time to time. Unless otherwise agreed, this document is used only as a guide, and all statements, information and recommendations in this document do not constitute any warranty, express or implied.

1.2 UPS Safety

- Before installing the equipment, wear insulating protective clothing, use insulating appliances, and remove conductive objects such as jewelry and watches to avoid electric shock or burns.
- The operating environment has a certain impact on the service life and reliability of UPS. The environmental requirements set in the manual must be followed when using and storing the equipment.
- Avoid using the equipment in direct sunlight, rain, or in environments with electrified dust.
- When placing UPS, maintain a safe distance around it to ensure ventilation. During operation of the system, do not block the vent.
- Do not allow liquids or other foreign objects to enter into the UPS cabinet or cabinet.
- Before using UPS, check whether the local distribution characteristics are consistent with the information of the product nameplate.
- As UPS is a large leakage current device, it is not recommended to install breakers with leakage protection function.
- Before connecting UPS, please further confirm whether the switch connecting the power supply of the UPS mains input/bypass power supply and the mains power are disconnected.
- When it is required to move or rewire UPS, make sure to disconnect AC input power supply, battery and other inputs, and UPS is fully powered down (more than 5min) before carrying out the corresponding operation, otherwise there may still be power in the port and inside of the equipment, and it is possible to cause a risk of electric shock.
- Before powering on, please confirm the correct grounding, and check wire connection and battery polarity to ensure correct connection. In order to ensure personal safety and the normal use of UPS, UPS shall be reliably grounded before use.
- UPS can be used for resistive and capacitive (such as computers), resistive and micro inductive load, not for pure capacitive and inductive load (such as motors, air conditioners and copiers) and half wave rectifier load.
- When cleaning the machine, please wipe it with a dry object. Under no circumstances shall water be used to clean electrical parts inside or outside the cabinet.
- After completion of maintenance operations, check immediately to ensure that no tools or other items are left in the cabinet.
- In case of fire, please use dry powder extinguisher correctly for extinguishment. There is a danger of electric shock if liquid fire extinguishers are used.
- Do not close the breaker before the UPS installation is completed. Do not power on UPS without the permission of a qualified electrician.





1.3 Battery Safety

- Battery installation and maintenance shall only be performed by personnel with battery expertise.

- There is danger of electric shock and short circuit current in the battery. In order to avoid safety accidents, when installing or replacing the battery, please pay attention to the following matters: do not wear jewelry and watches and other conductive objects; use special insulation tools; use facial protection; wear protective insulating clothing; do not turn the battery upside down or tilt it; disconnect the input breaker of the battery.
- The installation environment of the battery must be far away from the hot area, and it is not allowed to use or keep the battery near the fire source. The battery or battery strings cannot be processed by fire, otherwise it is possible cause personal injury due to explosion.
- Environmental factors impact battery life. Elevated ambient temperatures, poor quality utility power, and frequent short duration discharges will shorten battery life.
- The batteries should be regularly replaced to ensure the normal operation of UPS and sufficient backup time.
- Do not use a battery that is not approved by the supplier, as it may adversely affect the operation of the system. Use of a non supplier approved battery will void the manufacturer warranty.
- Check the screws of the connecting parts of the battery regularly to make sure they are tight and not loose. If the screws become loose parts, they must be tightened immediately.
- Please do not short the positive and negative terminals of the battery, otherwise it is possible to cause electric shock or fire.
- Do not touch the wiring terminal of the battery. The battery circuit is not isolated from the input voltage circuit, and there will be a high voltage hazard between the battery terminal and the ground.
- Do not open or damage the battery, otherwise it is possible to cause short circuit and battery leakage and the electrolyte in the battery may cause damage to the skin and eyes. In case of exposure into the electrolyte, wash immediately with plenty of water and go to the hospital for examination.

1.4 Description of Symbols

The following symbols used herein have the following meaning.

Symbols	Description
 DANGER	It is used to warn of emergency and dangerous situations which may lead to death or serious bodily injury if not avoided.
 WARNING	It is used to warn of potential dangerous situations which will lead to a certain degree of personal injury if not avoided.
 CAUTION	It is used to transmit the safety warning information of equipment or environmental, which may lead to equipment damage, data loss, equipment performance degradation or other unpredictable results if not avoided.
 NOTICE	It is used for further detailed description of the things, highlighting important/critical information, etc.

2 Product Overview

2.1 Working Principle

2.1.1 Schematic Diagram

40 kVA -120 kVA series UPS adopts on-line double conversion design based on DSP full digital control to provide customers with high efficiency and high power density power supply. Its functional block diagram is shown in Fig. 2-1.

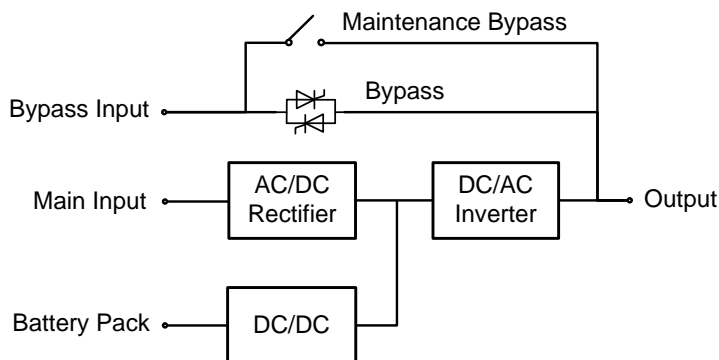

Fig. 2-1 Schematic diagram

2.1.2 Operating Mode

◇ Mains power mode

The mains power mode is the normal operating mode of UPS with following main operation process: the mains input voltage is rectified by the current rectifier, boosted to bus voltage by boosted circuit, and is partially used for charging the battery by DC/DC charger, and partially inverted to AC voltage output by an inverter to provide high quality, continuous and uninterrupted AC power. The working principle of mains power mode is shown in Fig. 2-2.

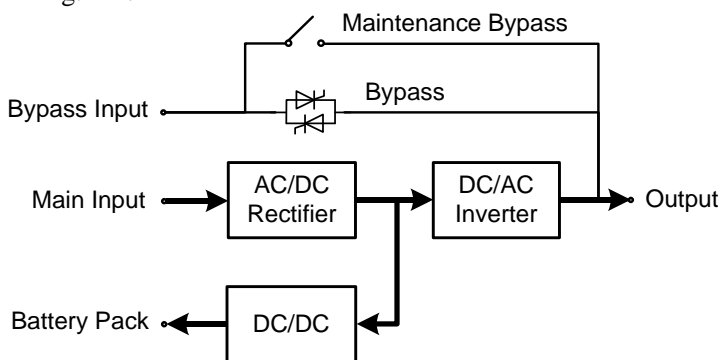

Fig. 2-2 Schematic diagram of mains power mode

◇ Bypass mode

In case of inverter failure, inverter overload or manual switching to bypass state and other faults or operations, UPS will switch the power output from the inverter side to the bypass side, and the bypass power will directly supply power to the load. In the bypass mode, the power supply for the load is not protected by UPS, which may lead to power failure if the bypass input is abnormal.

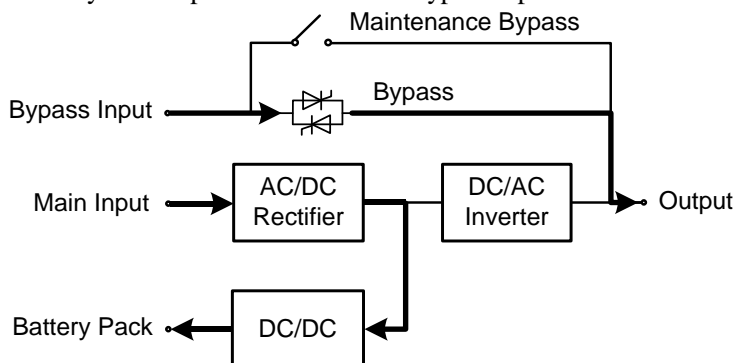

Fig. 2-3 Schematic diagram of bypass mode

◇ **Battery mode**

When the mains voltage is abnormal, UPS will automatically switch to battery mode. At this time, the power unit will obtain energy from the battery, boost the voltage through the booster circuit, and then provide AC voltage output to the load through the inverter, providing the load with continuous and uninterrupted high quality AC power supply. The operating principle of the battery mode is shown in Fig. 2-4.

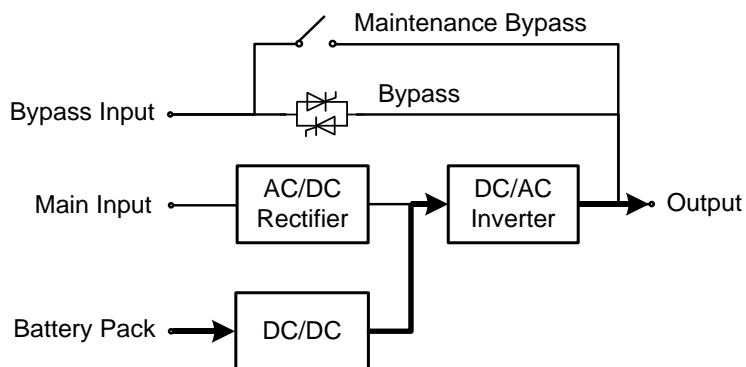

Fig. 2-4 Schematic diagram of battery mode

◇ **Maintenance bypass mode**

If it is required to maintain and repair UPS, the maintenance bypass breaker can be closed. UPS works in the maintenance bypass mode and supplies power through the maintenance bypass line rather than the main power unit. At this time, the replaceable unit in the machine can be maintained. The operating principle of the maintenance bypass mode is shown in Fig. 2-5.

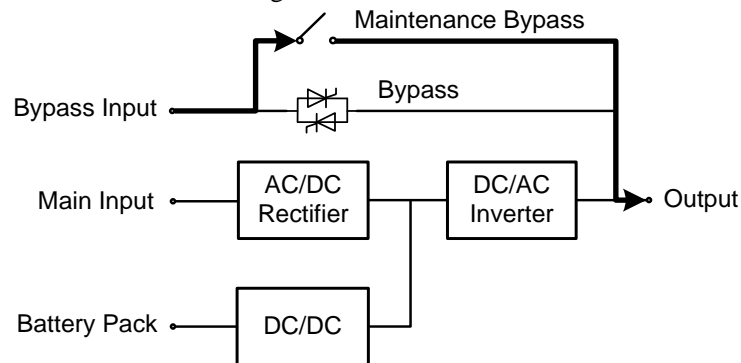

Fig. 2-5 Schematic diagram of maintenance bypass mode

◇ **ECO mode**

ECO mode is the economic operation mode of UPS, which can be set through LCD interface. In ECO mode, when the bypass input voltage is within the ECO voltage range, the power is supplied by the bypass and the inverter is in standby state. When the bypass input voltage exceeds the ECO voltage range, the power is supplied to the load by the inverter rather than the bypass. Either by - pass or inverter, the rectifier is on and the charger charges the battery. ECO has higher system efficiency. The working principle of ECO mode is shown in figure 2-6. Regardless of power supply by the bypass or the inverter, the rectifier is On and the battery is charged through the charger. ECO mode has higher system efficiency. The operating principle of ECO mode is shown in Fig. 2-6.

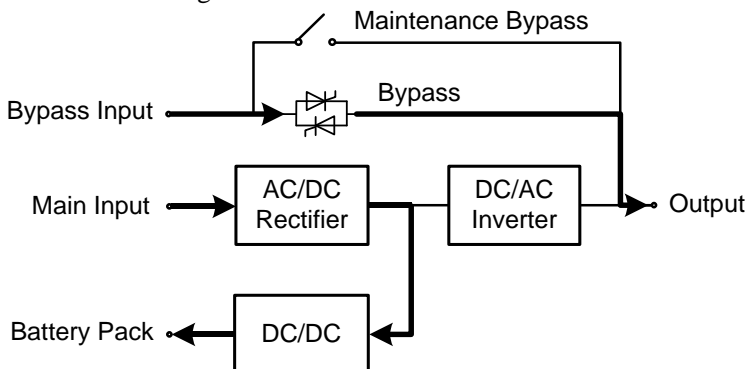

Fig. 2-6 Schematic diagram of maintenance ECO mode

2.2 System Structure

2.2.1 40 kVA / 60 kVA UPS System Structure

The appearance of 40 kVA / 60 kVA UPS is shown in Fig. 2-7.

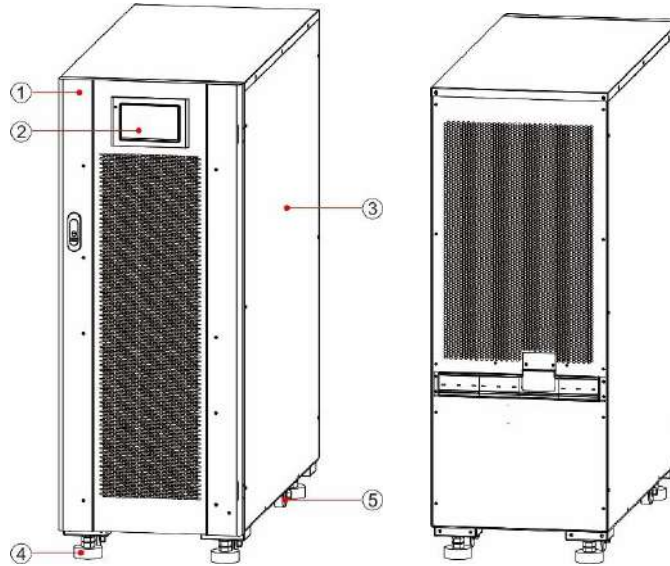

Fig. 2-7 Appearance of 40/60 kVA UPS

- | | | |
|----------------|---------------------------|-------------|
| 1 Front door | 2 Monitoring display unit | 3 Enclosure |
| 4 Support foot | 5 Wheels | |

The functional components of 40kVA/60kVA UPS are shown in Fig 2-8 and Fig. 2-9. Fig. 2-8 shows the state of the UPS whose front door panel is opened. In the figures 60 kVA UPS is used as an example, and a 40 kVA UPS has a single power module.

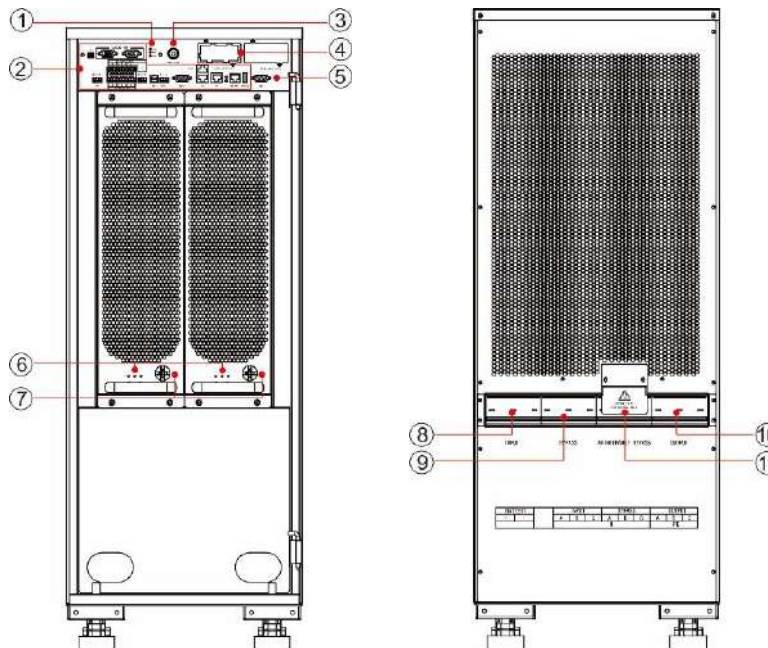

Fig. 2-8 Functional components of 40/60 kVA UPS (front view)

Fig. 2-9 Functional components of 40/60 kVA UPS (rear view)

- | | | |
|---------------------------------|-------------------------------------|-------------------------------|
| 1 System status indicator light | 2 Communication interface | 3 Cold start button |
| 4 Smart card slot | 5 Monitoring display unit interface | 6 Power unit indicator lights |
| 7 Power unit ready switch | 8 Mains input breaker | 9 Bypass input breaker |
| 10 Output breaker | 11 Maintenance bypass breaker | |

Indicator lights

The power unit indicator lights include the operation indicator light, the alarming indicator light, and the failure indicator light from left to right.

2.2.2 80 kVA / 120 kVA UPS System Structure

The appearance of 80 kVA/120 kVA UPS is shown in Fig 2-10. The figure of 120 kVA UPS is used as an example, and an 80 kVA UPS is narrower.

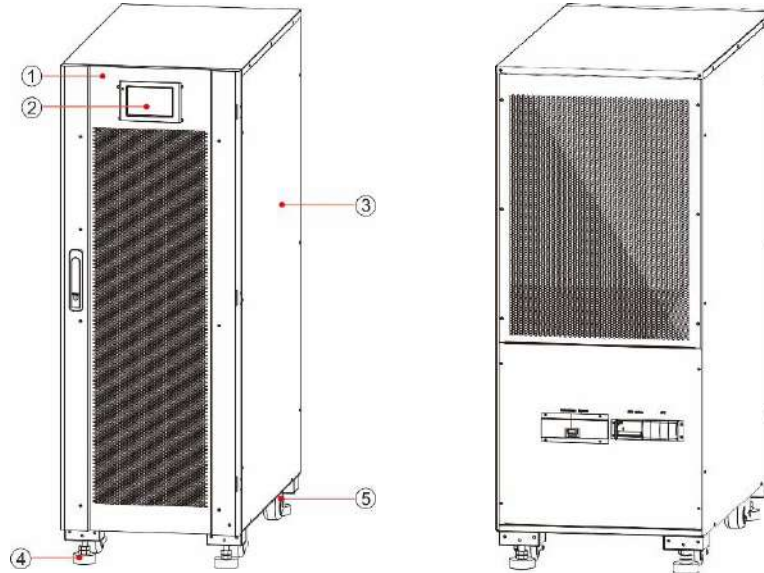

Fig. 2-10 Appearance of 80/120 kVA UPS

- | | | |
|----------------|---------------------------|-------------|
| 1 Front door | 2 Monitoring display unit | 3 Enclosure |
| 4 Support foot | 5 Wheels | |

The functional components of 80 kVA/120 kVA UPS are shown in Fig 2-11 and Fig. 2-12. Fig. 2-11 shows the state of UPS whose front door panel is opened. The figure of 120 kVA UPS is used as an example, and an 80 kVA UPS has two power modules.

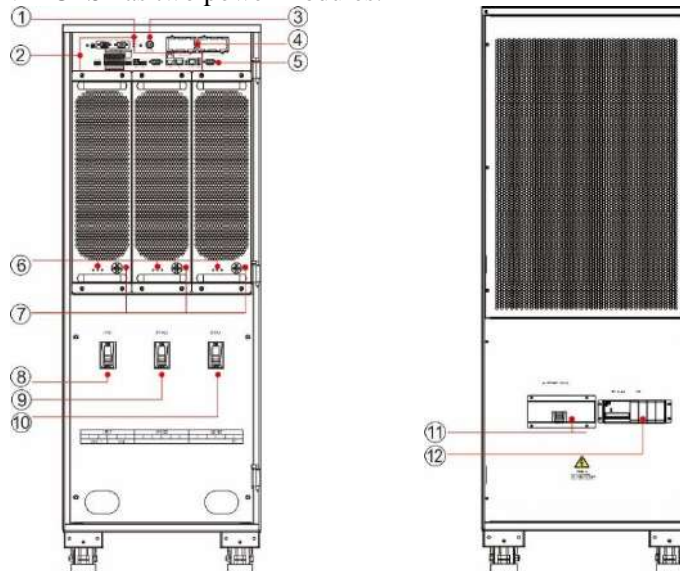

Fig. 2-11 Functional components of 120 kVA UPS (front view)

Fig. 2-12 Functional components of 120 kVA UPS (rear view)

- | | | |
|---------------------------------|-------------------------------------|-------------------------------|
| 1 System status indicator light | 2 Communication interface | 3 Cold start button |
| 4 Smart card slot | 5 Monitoring display unit interface | 6 Power unit indicator lights |
| 7 Power unit ready switch | 8 Mains input breaker | 9 Bypass input breaker |
| 10 Output breaker | 11 Maintenance bypass breaker | 12 Lightning protector |

2.3 Optional Accessories

Various optional accessories are provided for 40 - 120 kVA series UPS, as shown in Table 2-1, to meet different configuration requirements of users.

Table 2-1 Optional accessories of 40 - 120 kVA UPS

Optional accessories	Function
Wi-Fi card	It is used to achieve remote monitoring through Wi-Fi network, including operation status monitoring, emergency order release, system information reporting and other functions.
GPRS card	It is used to achieve remote monitoring through GPRS data networking, including operation status monitoring, emergency order release, system information reporting and other functions.
SNMP card	It is used to achieve remote monitoring through cable networking, including operation status monitoring, emergency order release, system information reporting and other functions.
4G card	It is used to achieve remote monitoring through 4G data networking, including operation status monitoring, emergency order release, system information reporting and other functions.
Battery monitor	It is used to inspect the voltage and temperature of the single battery and the charging and discharging of the battery string, and communicates with the upper computer by MODBUS communication protocol.
Battery temperature sensor	It is used to detect battery temperature, compensate the charging voltage according to the change the ambient temperature of the battery and prolong the service life of the battery.
Parallel connecting cable	It is used for connecting all UPS system for parallel operation.
LBS bus	It is used to the synchronizing signal transmission of the bus of the double bus system.

3 Installation

3.1 Installation Preparations

3.1.1 Site Preparations

Installation weight and dimensions

Ensure the ground or installation platform can bear the weight of UPS, the battery and battery rack. The weight of the battery and the battery rack shall be calculated according to the actual use condition. The installation weight and dimensions of UPS are shown in Table 3-1.

Table 3-1 Installation weight and dimensions of UPS

Model	Dimensions (W x D x H)	Weight
40 kVA	360 mm × 850 mm × 950 mm	95 kg
60 kVA	360 mm × 850 mm × 950 mm	125 kg
80 kVA	360 mm × 850 mm × 1200 mm	157 kg
120 kVA	440 mm × 850 mm × 1200 mm	192 kg

Installation environment

- Do not install UPS in high, low temperature or humid environment that exceed the technical specifications (see Chapter 8 Technical Parameters for environmental specifications).
- Keep UPS away from water source, heat source and inflammable and explosive materials. Avoid installing UPS in the environment with direct sunlight, dust, volatile gas, corrosive substances and excessive salt. It is strictly prohibited to install UPS in the working environment with metal conductive dust.
- If the UPS is installed in an airtight room without ventilation, it needs to be equipped with an air conditioning system to ensure stable ambient temperature. The cooling capacity of air conditioning should be greater than the sum of the heating sources in the room. The maximum heating capacity of this series UPS is 5% of the rated power value.

Clearance

A certain amount of operation and ventilation space shall be reserved around the cabinet. Reserve at least 450 mm space for ventilation and operation in the front, at least 300 mm space for operation in the top, and at least 300 mm space for ventilation at the back. If it is required to operate at the back, reserve at least 800 mm space. Take 40 kVA UPS as an example shown in Fig. 3-1.

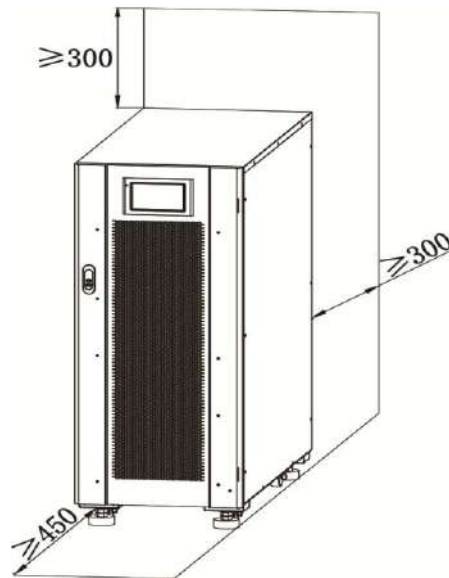



Fig. 3-1 Clearance of 40 kVA UPS (mm)

3.1.2 Installation Tools

	DANGER
	To ensure safety, installation tools for live operation shall be insulated.

Installation tools which may be used in installation process are shown in Table 3-2 and used as needed.

Table 3-2 Installation tools

Tool name	Main function	Tool name	Main function
Forklift	Handling	Nail hammer	Knock, install and remove components
Herringbone ladder	High-place operation	Rubber hammer	Knock and install components
Clip-on ammeter	Detect current	Percussion drill, drill bit	Drill
Multimeter	Check electrical connection and electrical parameters	Insulating tape	Electrical insulation
Cross screwdriver	Fasten screw	Heat-shrinkable tubing	Electrical insulation
Leveling instrument	Leveling	Heat gun	Heat heat-shrinkable tubing
Insulated monkey wrench	Tighten and loosen bolts	Electrician's knife	Wire stripping
Insulated torque wrench	Tighten and loosen bolts	Cable tie	Bundle
Crimping pliers	Cc cold-pressed terminal	Leather working gloves	Protect operator's hands
Hydraulic clamp	Clamp OT terminal	Antistatic gloves	Anti-static
Diagonal pliers	Shear cables	Insulating gloves	Insulation
Wire stripper	Wire stripping	Insulated protective shoes	Protect operator

3.1.3 Preparation of Power Cables

The recommended cable sizes are shown in Table 3-3, the requirements of cable terminals are shown in Table 3-4, and the recommended configurations of input-output breakers are shown in Table 3-5.

Table 3-3 Recommended cable sizes

Item		40 kVA	60 kVA	80 kVA	120 kVA	
Mains input	Mains input current (A)	71	107	142	213	
	Recommended diameter (mm ²)	A/B/C/N	4×16	4×35	4×50	4×70
Bypass input	Bypass input current (A)	61	91	122	182	
	Recommended diameter (mm ²)	A/B/C/N	4×16	4×25	4×35	4×70
Output	Output current (A)	61	91	122	182	
	Recommended diameter (mm ²)	A/B/C/N	4×16	4×25	4×35	4×70
Battery input	Discharge current of 32 x 12V batteries (A)	110	164	219	329	
	Recommended diameter (mm ²)	BAT+/BAT-/N	3×35	3×70	3×95	3×150
Grounding cable	Recommended diameter (mm ²)	PE	1×16	1×16	1×25	1×50

 **Note**

- The cables recommended in Table 3-3 are only applicable to the following conditions:
 - Laying method: installed on the wall or floor (IEC60364-5-52)
 - Ambient temperature: 0 - 30 °C
 - AC voltage loss is less than 3%, DC voltage loss is less than 1%. The DC and AC cables of in the table is not more than 20 m long and for 60 kVA ~ 120 kVA UPS, the AC cables is not more than 30 m long, and the DC cables is not greater than 40 m
 - 90°C copper core cable
- When the main and the bypass are same, the input cable is configured according to the mains input cable.
- The current value in the table refers to the data obtained at rated voltage 380V. The current value needs to be multiplied by 0.95 for the rated voltage 400V, and 0.92 for 415 V rated voltage.
- When the main load is non-linear load, the n-line section needs to be increased by 1.5-1.7 times.

	WARNING
	<ul style="list-style-type: none"> • When OT terminals and DT terminals are selected, please strictly follow the parameters specifications as given in Table 3-4 to avoid short circuit. • When connecting the power cable, to comply with the torsion moment, given in table 3-4 to ensure the tightness of terminals, to avoid potential safety hazard.

Table 3-4 Requirements of cable terminals

Model	Interface description	Connection mode	Bolt specification	Bolt hole	Torque
40 kVA	Mains input	Cable crimping with OT Terminal	M8	9 mm	13 N m
60 kVA		Cable crimping with DT Terminal	M8	9 mm	13 N m
80 kVA		Cable crimping with DT Terminal	M8	9 mm	13 N m
120 kVA		Cable crimping with DT Terminal	M10	11 mm	27 N m
40 kVA	Bypass input	Cable crimping with OT Terminal	M8	9 mm	13 N m
60 kVA		Cable crimping with OT Terminal	M8	9 mm	13 N m
80 kVA		Cable crimping with DT Terminal	M8	9 mm	13 N m
120 kVA		Cable crimping with DT Terminal	M10	11 mm	27 N m
40 kVA	Battery input	Cable crimping with DT Terminal	M8	9 mm	13 N m
60 kVA		Cable crimping with DT Terminal	M8	9 mm	13 N m
80 kVA		Cable crimping with DT Terminal	M8	9 mm	13 N m
120 kVA		Cable crimping with DT Terminal	M10	11 mm	27 N m
40 kVA	Output	Cable crimping with OT Terminal	M8	9 mm	13 N m
60 kVA		Cable crimping with DT Terminal	M8	9 mm	13 N m
80 kVA		Cable crimping with DT Terminal	M8	9 mm	13 N m
120 kVA		Cable crimping with DT Terminal	M10	11 mm	27 N m
40 kVA	Protective grounding	Cable crimping with OT Terminal	M8	9 mm	13N m
60 kVA		Cable crimping with OT Terminal	M8	9 mm	13N m
80 kVA		Cable crimping with OT Terminal	M8	9 mm	13N m
120 kVA		Cable crimping with DT Terminal	M10	11 mm	27N m

Table 3-5 Configurations of input-output breakers

Input-output breaker	40 kVA	60 kVA	80 kVA	120 kVA
Mains input breaker (standard configuration)	100 A / 3P	125 A / 3P	160 A / 3P	250 A / 3P
Bypass input breaker (standard configuration)	100 A / 3P	125 A / 3P	160 A / 3P	250 A / 3P
Output breaker (standard configuration)	100 A / 3P	125 A / 3P	160 A / 3P	250 A / 3P
Battery input breaker (recommended)	DC 160 A / 3P	DC 200 A / 3P	DC 250 A / 3P	DC 400 A / 3P

Note

- The mains input breaker, the bypass input breaker and the output breaker are installed in this product as standard configuration.
- As UPS is a large leakage current device, it is not recommended to install breakers with leakage protection function.
- When the input front end is provided with multiple loads, the specification of circuit breaker for the front-level bus configuration must be greater than the specification of the mains input breaker and the bypass input breaker of UPS.
- When the input rear end is provided with multiple loads, the specification of circuit breaker for the front-level bus configuration must be smaller than the specification of the input breaker of UPS.

3.1.4 Unpacking

	CAUTION
	<ul style="list-style-type: none"> • The equipment must be handled by specially trained personnel. • Handle the equipment with care, and the device. Any impact or fall may cause damage to the equipment.

Procedures:

Step 1: make sure the UPS package is not damaged. In case of any damage during transportation, please inform the carrier immediately.

Step 2: use the forklift to transport the equipment to the designated location.

Step 3: remove outer packing and remove buffer foam.

Step 4: remove the moisture barrier bag.

Step 5: check the integrity of the equipment.

Inspect the appearance of UPS, and check whether UPS is damaged during transportation. If yes, please notify the carrier immediately. Check whether the attached accessories are complete and correct according to the packing list. If the accessories are short or the model is not in accordance with the requirements, timely make on-site records and immediately contact the company or the local office.

Step 6: after confirming that the equipment is in good condition, remove the L-shaped angle support fixed by pallet for fixing the case, as shown in Fig. 3-2.

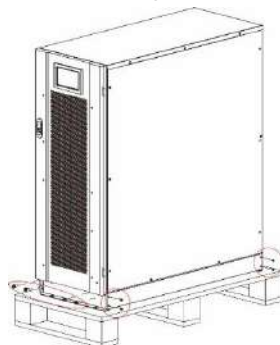

Fig. 3-2 Removal of L-shaped angle support

Step 7: turn the wrench counterclockwise to raise the four support feet at the bottom of UPS until all the four wheels at the bottom of the case are evenly landed and the support feet are completely suspended. See Fig. 3-7.

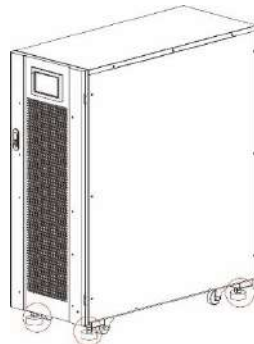

Fig. 3-3 Upward adjustment of support feet

Step 8: use the automatic lift forklift or other equipment to unload the machine, and move the equipment to the installation position by a roller.

3.2 Installation of Single UPS System

3.2.1 UPS Installation

Installation procedures:

Step 1: turn the wrench clockwise to lower the four support feet at the bottom of UPS until all the four wheels at the bottom of the case are suspended and the equipment is fully supported by the support feet.

Step 2: check the level of the case with the leveling instrument. If not, continue to adjust the support feet until reaching the level state.

3.2.2 Install Tightening Components

The tightening components are installed for vibration and impact resistance, and can be selectively installed according to the installation environment. The specific installation procedure is as follows:

Step 1: determine the installation position and position the mounting surface according to the hole size diagram. The hole size is shown in Fig. 3-4 and Fig. 3-5.

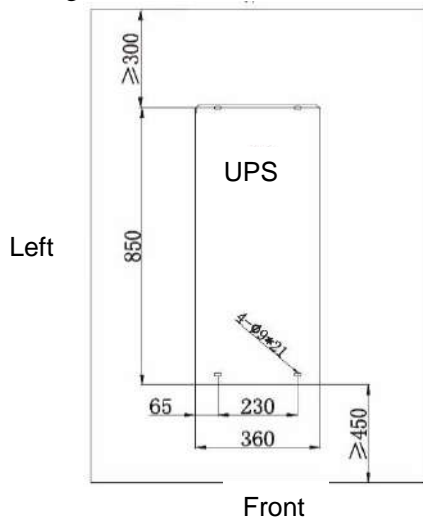

Fig. 3-4 Hole size of 40/60/80 kVA

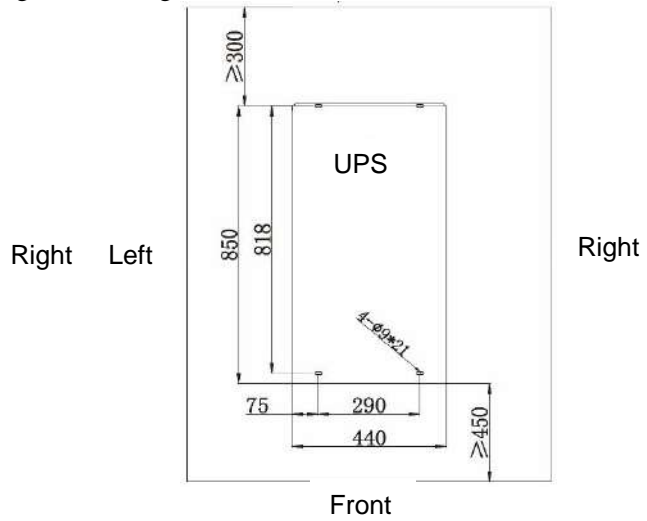

Fig. 3-5 Hole size of 120 kVA

Step 2: selectively install expansion bolt holes and expansion bolts according to the site conditions of installation foundation.

Step 3: handle the UPS to the installation position with the roller.

Step 4: turn the wrench clockwise to lower the four support feet at the bottom of UPS until all the four wheel at the bottom of the case are suspended and the equipment is fully supported by the support feet.

Step 5: open the front door and remove the cover panel of the distribution unit, as shown in Fig. 3-6 and Fig. 3-7.

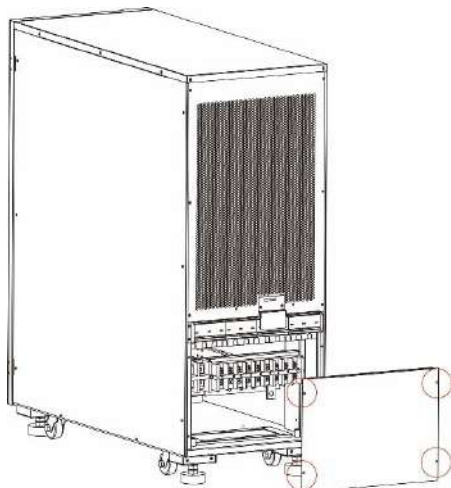

Fig. 3-6 Remove the cover of distribution unit (40/60 kVA)

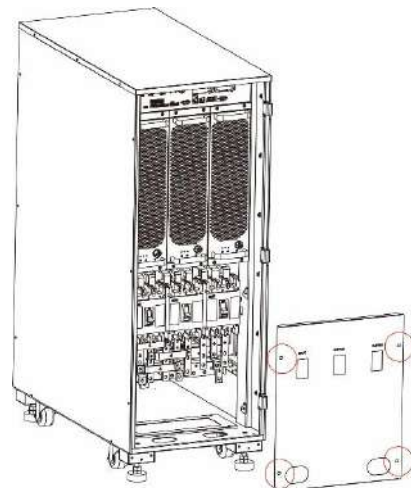

Fig. 3-7 Remove the cover of distribution unit (80/120 kVA)

Step 6: secure the components to the case with 8 x M6 and 4 x M12 screws, as shown in Fig. 3-8.

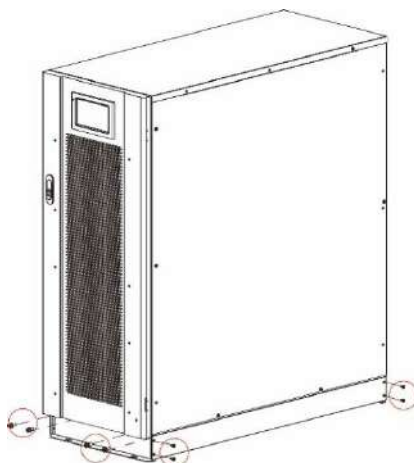

Fig. 3-8 Fix the tightening components on the case

Step 7: fine-tune the case so that the expansion bolts are aligned with the four holes.

Step 8: secure the tightening components in the front and back of the case to the ground with 4 M12×60 expansion bolts.

Step 9: close the front door and put the cover panel of the distribution unit back into the case.

3.2.3 Install Batteries

Please refer to the battery installation instructions shipped with the battery for methods.

After the battery is installed, check the voltage of a single battery, normal range: 10.5 V -13.5 V; Check the voltage difference between single cell in a series battery string, generally no more than 5%. If not, charge or replace the battery.

3.2.4 Connect Power Cables

Step 1: remove the cover plate of distribution unit (80kVA/120kVA need to open the front door first), as shown in Fig. 3-6 and Fig. 3-7.

Step 2: connect power cables.

- The wiring position and path of the power cable at the bottom of the cabinet are shown in Fig. 3-9 and Fig. 3-10.

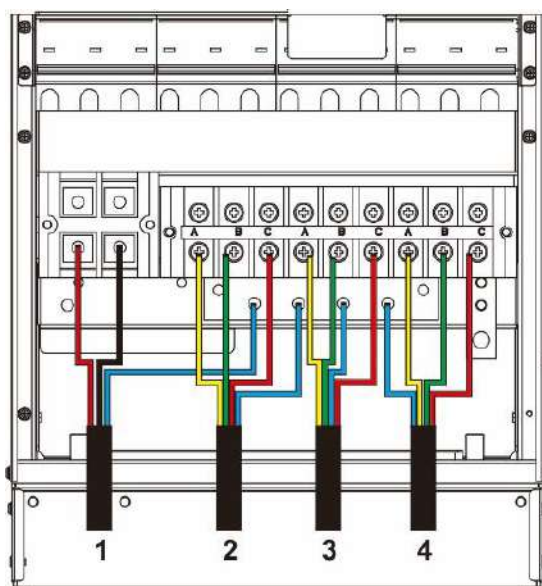

Fig. 3-9 Wiring of power cable (40/60 kVA)

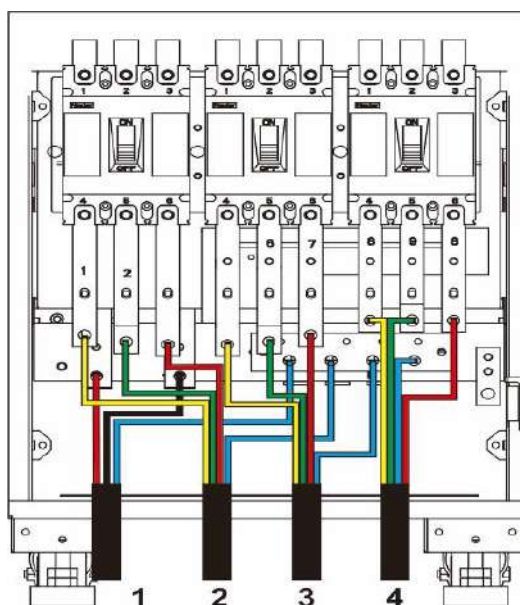



Fig. 3-10. Wiring of power cable (80/120 kVA)

- | | | | | | |
|---|---------------------|---|-------------------|---|--------------------|
| 1 | Battery input cable | 2 | Mains input cable | 3 | Bypass input cable |
| 4 | Output cable | | | | |

• Connection of battery cable

	CAUTION
<ul style="list-style-type: none"> • Battery voltage can be fatal. Please observe safety instruction during connecting cables. • Select total number of batteries from 30 to 46 (even number), and the number of positive and negative battery strings must be consistent. • Positive and negative battery strings must be equipped with a 3-channel battery breaker with limited current protection. • During wiring, ensure that the polarity of the cable connecting the battery terminal to the battery breaker and the battery breaker to the UPS terminal is correct. 	

The reference connection mode of the battery strings is shown in Fig. 3-11, where the N line of the battery is the reference potential leading from the connection point in the middle of positive and negative battery strings.

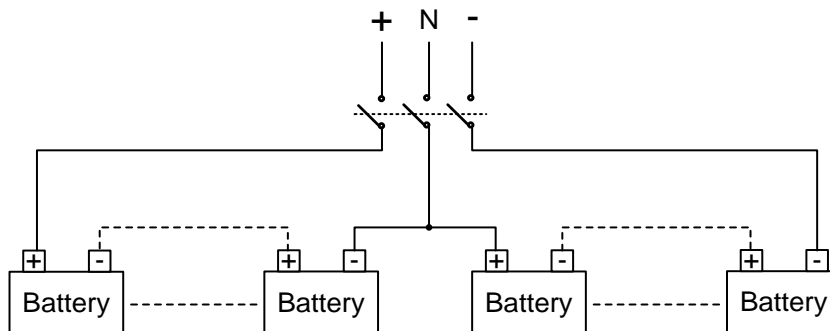

Fig. 3-11 Wiring diagram of battery strings

Connect the battery cable of the battery string to the +, N and - of the battery distribution terminal, as shown in Fig. 3-12 and Fig. 3-13.

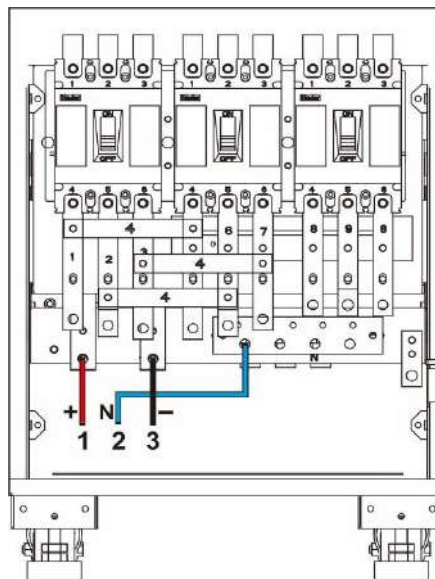
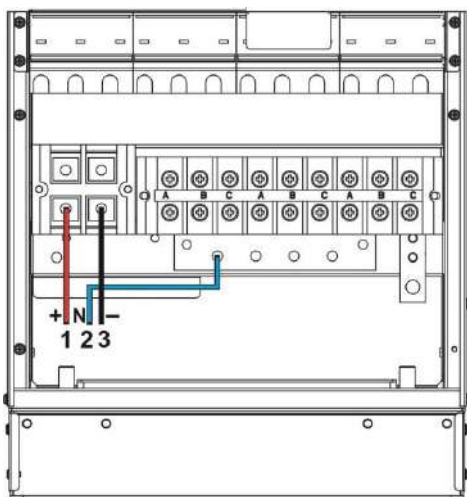

Fig. 3-12 Connection of battery cable (40/60 kVA)

Fig. 3-13 Connection of battery cable (80/120 kVA)

- 1 Battery input +
- 2 Battery input N
- 3 Battery input -

• Connection of AC input cable

◇ Different power supply for main and bypass

Before performing the following steps, please measure with a multimeter to ensure that the three-phase terminals of the main circuit and the bypass circuit are not short-circuited.

Step 1: connect the mains input cables to the main distribution terminals A, B, C and N successively.

Step 2: connect the bypass input cables to the bypass distribution terminals A, B, C and N successively, as shown in Fig. 3-14 and 3-15.

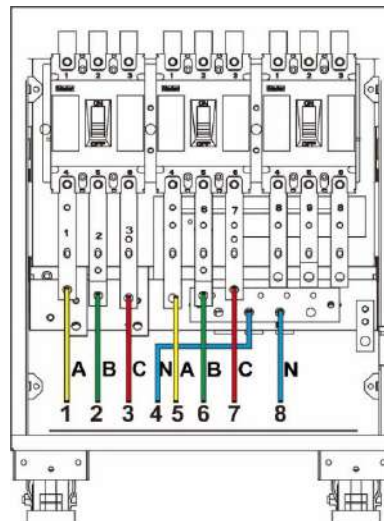
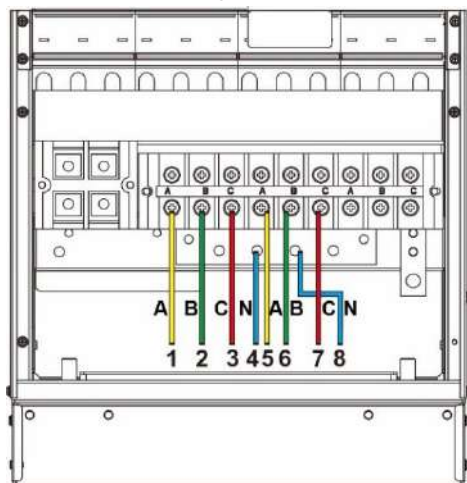

Fig. 3-14 Connect AC input cable (40/60 kVA)

Fig. 3-15 Connect AC input cable (80/120 kVA)

- | | | | |
|------------------|------------------|------------------|------------------|
| 1 Mains input A | 2 Mains input B | 3 Mains input C | 4 Mains input N |
| 5 Bypass input A | 6 Bypass input B | 7 Bypass input C | 8 Bypass input N |

◇ Same power supply for main and bypass

Step 1: Install connection cables or copper bars between mains input and bypass input terminals, as shown in Figs. 3-16 and 3-17.

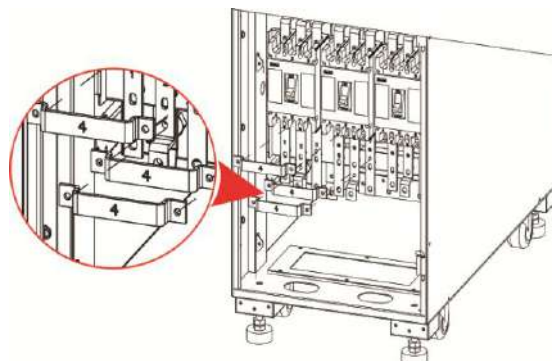
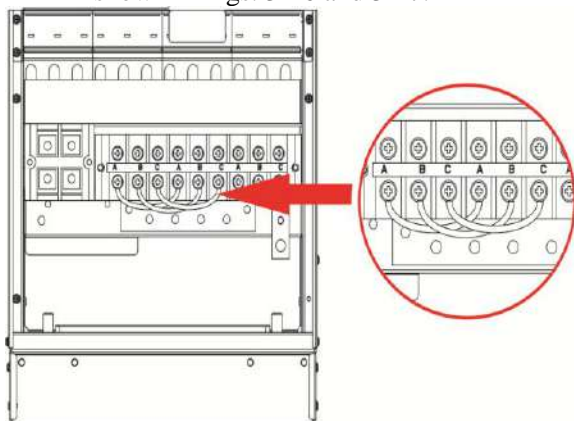

Fig. 3-16 Install connection cables (40/60 kVA)

Fig. 3-17 Install copper bars (80/120 kVA)

Step 2: Connect the AC input cables successively to distribution terminal A, B, C and N of, as shown in Fig. 3-18 and Fig. 3-19.

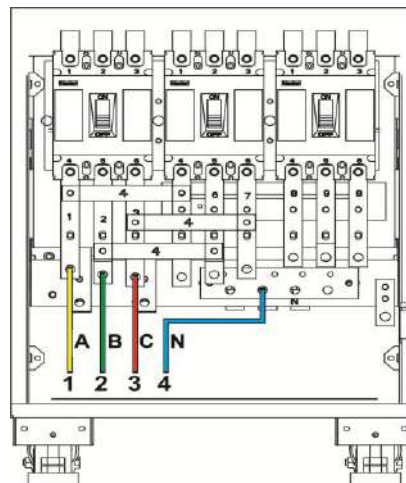
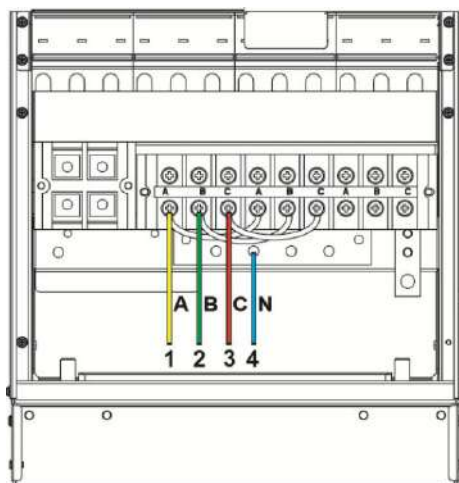

Fig. 3-18 Connect AC input cable (40/60 kVA)

Fig. 3-19 Connect AC input cable (80/120 kVA)

- | | | | |
|-----------|-----------|-----------|-----------|
| 1 Input A | 2 Input B | 3 Input C | 4 Input N |
|-----------|-----------|-----------|-----------|

- Connection of AC output cable

Connect the output cables successively to the output distribution terminals A, B, C and N, as shown in Fig. 3-20 and Fig. 3-21.

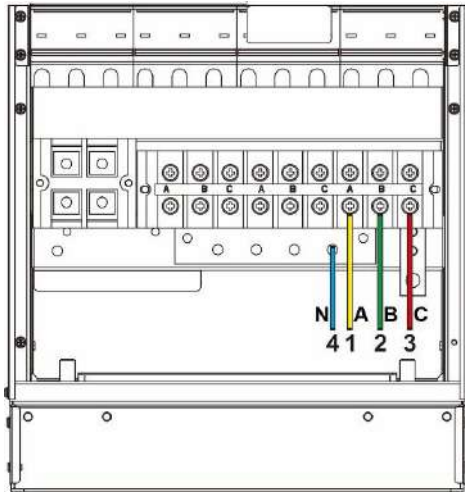

Fig.3-20 Connect AC output cable (40/60 kVA)

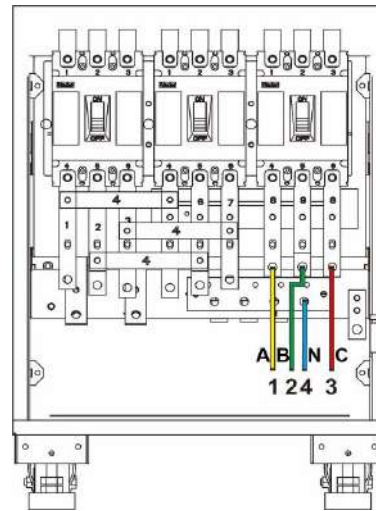

Fig. 3-21 Connect AC output cable (80/120 kVA)

- | | | | | | |
|---|----------|---|----------|---|----------|
| 1 | Output A | 2 | Output B | 3 | Output C |
| 4 | Output N | | | | |

3.2.5 Connect Grounding Cable

Connect the grounding cable of UPS as shown in Fig. 3-22 and Fig. 3-23. An additional M8 ground port is also reserved on the left side.

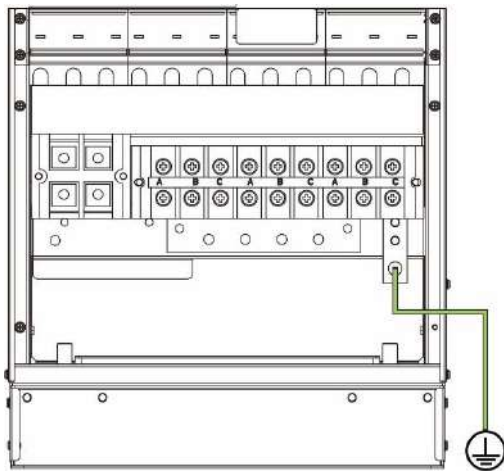

Fig. 3-22 Connect grounding cable (40/60 kVA)

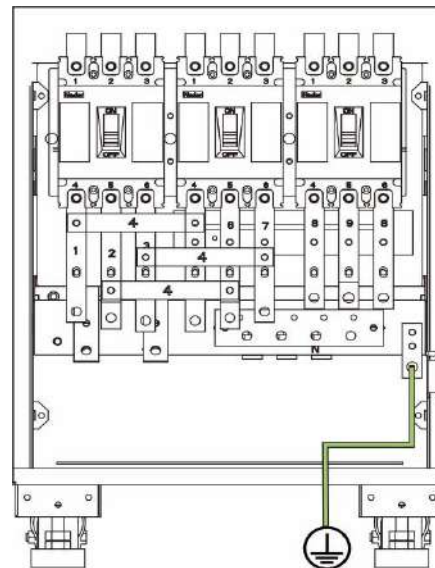

Fig. 3-23 Connect grounding cable (80/120 kVA)

3.2.6 Communication Signal Interface

General

40 - 120 kVA series UPS integrates communication slot, FE network port, RS485 interface, parallel operation interface, LBS interface, basic dry contact access and other communication signal interface. Functional components and communication signal interfaces are shown in Fig. 3-24.

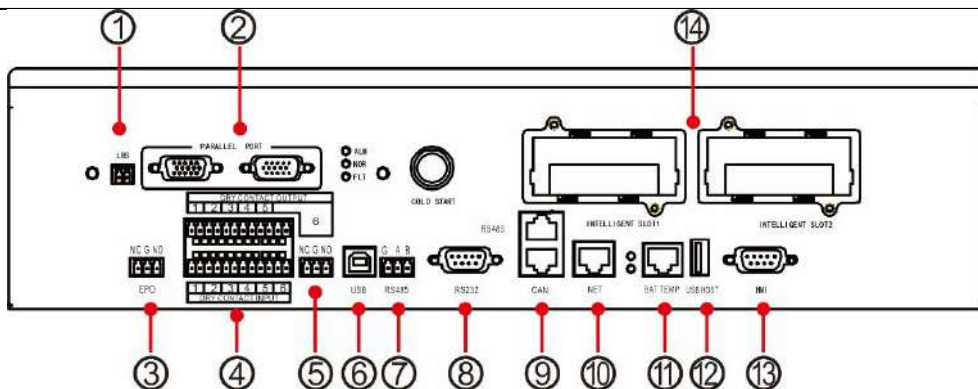

Fig. 3-24 Functional components and communication signal interfaces

- | | | |
|--------------------------------------|---|--|
| 1 LBS interface | 2 Parallel operation interface | 3 EPO interface |
| 4 Dry contact interface | 5 Dry contact interface (HV) | 6 USB interface |
| 7 RS485 interface | 8 RS232 interface | 9 Battery itinerant detector interface |
| 10 NET interface | 11 Battery temperature sensor interface | 12 USB device interface |
| 13 Monitoring display unit interface | 14 Smart card slot | |

Parallel operation interface and LBS interface

When parallel operation is needed, parallel operation control cable shall be used to connect the parallel connection interface of each single UPS in a circular way, and no connection is needed for the single UPS. LBS is used in the dual bus system to process the communication information of two UPS systems. Specific functions are shown in Table 3-6.

Table 3-6 Function of parallel operation interface and LBS interface

Panel silk-screening	Description
PARALLEL PORT	Inter host parallel signal interface. When multiple UPSs are connected in parallel, the parallel operation interface of each UPS shall be annular connected with parallel operation control cables. N parallel operation control cables shall be used to connect N UPSs, so as to ensure that each UPS is connected with at least two parallel operation control cables and improve parallel operation reliability.
LBS	LBS is used in the double-bus system to balance the output frequency and phase of each system in the double-bus system to ensure change between two buses.

Dry contact interface

Through the dry contact interface of UPS, it is possible to achieve functions such as monitoring status of the external device, managing the battery system, providing warning signal to the external device and remote emergency shutdown. The dry contact interface of the equipment can be customized. The default is none. User-defined dry contact and corresponding functions are shown in Table 3-7.

Table 3-7 Function of dry contact

Dry contact	Signal description	Status description	Function description
Dry contact input DI_1~DI_6	Battery ground fault	It is disconnected in initial status. Its disconnection showing no battery ground fault and its connection showing the battery ground fault.	Battery grounding status detection. In case of the ground failure, UPS will give an alarm.
	Oil machine model	It is disconnected in initial status. Its disconnection showing non-oil machine model and its connection showing the oil machine model.	Oil machine working state detection. In oil machine mode UPS improves the relevant adaptability.
	Battery breaker state	It is disconnected in initial status. Its disconnection showing the battery breaker disconnected, and its connection showing the battery breaker connected.	Status detection. UPS will give an alarm when the battery breaker is disconnected.
	Outputs breaker status of distribution cabinet	It is connected in initial status. Its connection showing the output breaker connected and its disconnection showing the output breaker disconnected.	Status detection. UPS will give an alarm when the output breaker of the distribution cabinet is disconnected.
	Maintenance switch status of distribution cabinet	It is disconnected in initial status. Its disconnection showing the maintenance switch connected, and its connection showing the maintenance switch disconnected.	Status detection. UPS will switch to the bypass and give an alarm when the maintenance switch of the distribution cabinet is disconnected.
	Bypass breaker status of distribution cabinet	It is connected in initial status. Its connection showing the bypass breaker connected and its disconnection showing the bypass breaker disconnected.	Status detection. UPS will give an alarm when the bypass breaker of the distribution cabinet is disconnected
	AC lightning protector status	It is connected in initial status. Its connection showing the AC lightning protector in normal status and its disconnection showing the AC lightning protection failed.	Status detection. UPS will give an alarm in case of the failure in the lightning protector.
	External transformer overheat	N/A for this equipment type	N/A for this equipment type
Dry contact out DO_1~DO_6	Emergency alarm	It is connected in initial status. Its connection showing no emergency alarm of UPS and its disconnection showing the emergency alarm of UPS.	Status information whether output has the failure warning of the machine.
	Secondary alarm	It is connected in initial status. Its connection showing no secondary alarm of UPS and its disconnection showing the secondary alarm of UPS.	Status information whether output has non-failure warning of the machine.
	Bypass power supply	It is connected in initial status. Its connection showing non- bypass power supply of UPS and its disconnection showing the bypass power supply of UPS.	Status information whether output is from the bypass power supply.
	Battery power supply	It is connected in initial status. Its connection showing non- battery power supply of UPS and its disconnection showing the battery power supply of UPS.	Status information whether output is from the battery power supply.

Dry contact	Signal description	Status description	Function description
	Battery low DOD	It is connected in initial status. Its connection showing battery voltage of UPS in normal status and its disconnection showing the battery low of UPS.	Status information whether output is battery low
	Battery low EOD	It is connected in initial status. Its connection showing UPS battery in normal status and its disconnection showing battery discharging completed.	Status information whether the discharging of the output battery is completed.
	Oil machine control	It is connected in initial status. Its connection showing non-oil machine control of UPS and its disconnection showing oil machine control of UPS.	When the mains input is abnormal, the starting signal is output to the oil machine in the battery mode.
	Battery breaker tripped	It is connected in initial status. Its connection showing the battery breaker not tripped and its disconnection showing the battery breaker tripped.	Before battery EOD is OFF, act to disconnect the battery breaker for battery protection.
	Bypass failure	It is connected in initial status. Its connection showing non- bypass failure and its disconnection showing bypass failure.	Status information whether output bypass fails.
	Fan failure	It is connected in initial status. Its connection showing non-fan failure and its disconnection showing fan failure.	Status information whether output fan fails.
	Time-division Off	It is connected in initial status. Its connection showing time-division Off and its disconnection showing time-division Off.	In case of power failure in both main circuit and the bypass, the battery supplies the power to DOD, and action signal is output.
Emergency Power Off (EPO)	Emergency shutdown NC signal interface	It is connected in initial status. EPO disconnection triggering the emergency shutdown.	Emergency shutdown status detection
	Common end G		
	Emergency shutdown NO signal interface	The precondition is that NC end and G end are always connected. It is connected in initial status. EPO connection triggering the emergency shutdown.	
	Common end G		

Note

- DI_1 ~ DI_6 represent dry contact input interface 1 ~ 6, DO_1 ~ DO_6 represent the dry contact output interface 1 ~ 6.
- NO represents normally open end, and NC represents the normally close end.
- The dry contact output DO_6 is high withstand-voltage dry contact output interface which can withstand maximum 250 Vac, and defaults to NC interface. If NO interface is selected for wiring, the status logic is in contrast to the one of dry contact provided in the above stable.
- When a dry contact signal cable of external equipment is connected to the dry contact interface of UPS, it is required to ensure the full corresponding of the dry contacts at two ends of the cable.
- NO signal end is recommended for connection of remote EPO to avoid UPS failure resulting from the failure of connecting cable. In order to avoid misoperation, the emergency stop button shall be protected by an anti-misoperation cover plate, and the connecting cable shall be protected by the pipe.

Communication signal interface

Through the communication signal interface, connection and communication with external devices can be realized, so that UPS can be monitored and managed, as well as complete other functional interactions. The functions of the communication signal interface are shown in Table 3-8.

Table 3-8 Functions of the communication signal interface

Signal interface	Panel silk-screen	Function description
USB interface	USB	Connect local host via USB for local monitoring communication.
RS485 interface	RS485	Connect local host through RS485 for local monitoring communication.
RS232 interface	RS232	Connect local host through RS232 for local monitoring communication.
Battery monitor interface / BMS interface of lithium-ion battery groups	RS485	Connect the battery monitor via RS485 to realize the status detection of each single battery or connect lithium-ion battery groups via RS485 to realize the communication management of lithium battery groups.
	CAN	Connect the battery monitor via CAN to realize the status detection of each single battery or connect lithium-ion battery groups via CAN to realize the communication management of lithium battery groups.
NET interface	NET	Connect local host or LAN via NET port to debug and configure UPS or monitor the LAN.
Battery temperature sensor interface	BAT TEMP	Connect the battery temperature sensor through the RJ45 interface to detect battery temperature.
USB device interface	USB HOST	Connect USB device (U disk, etc.) through USB flash disk to upload and online upgrade the program, or download the history.
Monitoring display unit interface	HMI	Connect the monitor display unit through DB9 interface to realize UPS control and status display.

Optional function cards in smart card slots

Optional smart cards: SNMP card, GPRS card and Wi-Fi card etc.

The smart cards are installed in the optional card slot of UPS, which support hot-plug and feature convenient installation. Proceed as follows:

Step 1: first remove the cover plate from the intelligent slot;

Step 2: insert the required smart card into the slot;

Step 3: lock the smart card with previously removed screws.

- **SNMP card** is compatible with today's popular Internet software and firmware and network operating system and provide direct the direct Internet access function for UPS to provide instant UPS data and power supply information, and achieve communication and management by communication network management systems, the network communication of UPSs and convenient centralized monitoring and management of each UPS. Please refer to supporting operation instruction for details.
- **4G card** allows UPS to connect the Internet through 4G data (local SIM card is required), and the server for data communication, and UPS may be monitored online through computer or mobile phone. Please refer to supporting operation instruction for details
- **GPRS card** allows UPS to connect the Internet through GPRS data (local SIM card is required), and the server for data communication, and UPS may be monitored online through computer or mobile phone. Please refer to supporting operation instruction for details
- **Wi-Fi card** allows UPS to connect the Internet through Wi-Fi and the server for data communication, and UPS may be monitored online through computer or mobile phone. Please refer to supporting operation instruction for details

3.3 Installation of Parallel UPS System

3.3.1 Connect Power Cables

Wiring procedures:

As shown in the figure, respectively connect the mains power input, bypass input, output and battery of the UPS to be connected in parallel, and then connect the mains power, the bypass, the battery and the load respectively.

Step 1: properly install the AC input cables and the battery cables of each UPS in the parallel system as shown in 3.2.4.

Step 2: ground the single UPS of each parallel system separately. See 3.2.5 for the grounding method.

Step 3: connect the mains power input, bypass input, output and battery of UPS to be connected in

parallel, and then connect the mains power, the bypass, the battery and the load respectively. The power wiring diagram of the parallel system is shown in Fig. 3-25.

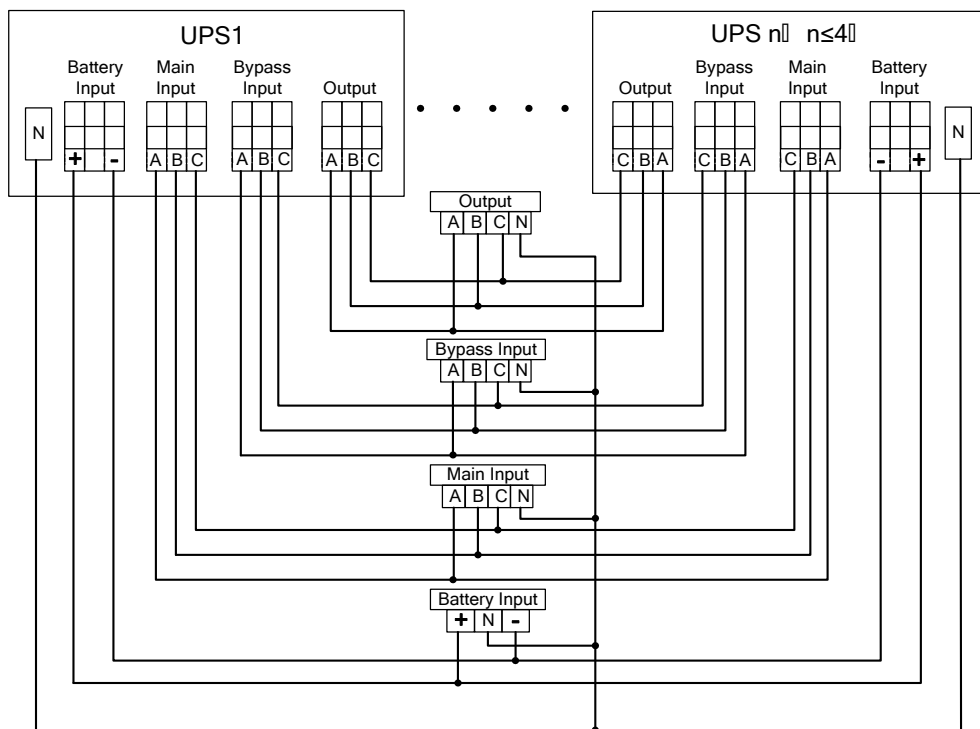

Fig. 3-25 Schematic diagram for power wiring diagram of parallel system

Note

- If the parallel system shares the battery string, it is required to set to battery strings sharing in the system.
- During wiring, connect the power cables with the distribution terminals of UPS one by one according to the screen-printed corresponding relationship.
- The length and specification of each power cable should be as same as possible, including bypass input cable and UPS output cable, so as to achieve even current in bypass mode.

3.3.2 Connect Control Cables

Connect parallel control cables

Connect the parallel interface of single UPS of the parallel system to form a loop by the parallel control cable.

Exampling 1+1 parallel system, the wiring diagram is shown in Fig. 3-26 and 3-27.

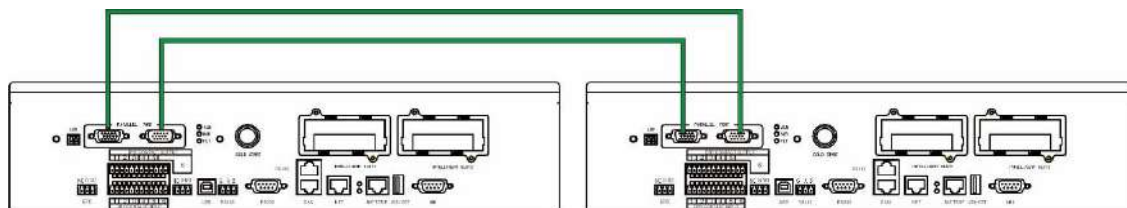

Fig. 3-26 Wring diagram for control cables of 1+1 parallel system

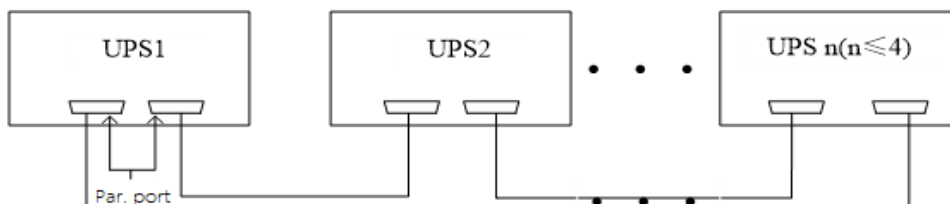

Fig. 3-27 Wring diagram for control cables of parallel system

Connect other control cables

Connect the control cables of single UPS in the parallel system according to "3.2.6 communication signal interface".

3.4 Installation Inspection

The inspection items and acceptance criteria are shown in Table 3-9.

Table 3-9 Inspection items and acceptance criteria

No.	Inspection items	Acceptance criteria
01	Inspect whether the system configuration is consistent with the delivery.	The model number of the field system and the number of units shall be consistent with the those provided in contract .
02	Inspect whether future system cabling is considered during wiring	The cabling is reasonable and conforms to the construction requirements.
03	Inspect whether the input cable, the output cable and the battery connection cable are connected securely.	All cable connections shall be not loose, and during fastening screws, make sure that the spring pads are pressed flat to prevent falling off or safety accidents, and ensure that there are no open circuit and hidden trouble points in the connection.
04	If the equipment is remotely managed, check that the associated serial port (which supports security mechanisms) is connected correctly.	The control cable must be corrected properly and tightened.
05	Inspect whether the cable mark is clear and accurate.	Both ends of the cable should be marked, and the label should be concise and easy to understand.
06	Inspect whether the ground wire of UPS is connected to the ground wire row in the machine room and whether the ground wire connection is reliable.	It is required to connect securely the grounding bar in the machine room.
07	Check the connection of each cable.	Check the connection of the circuit against the circuit diagram.
08	Inspect whether the input live wire and zero wire are connected inversely	The live wire and the zero wire must be correct properly.
09	For single UPS, inspect whether the phase sequence of the input live wire is correct; for parallel operation, inspect whether the phase sequence of main and bypass input and output live wires of each UPS is consistent .	For single UPS, the phase sequence of the live wire of UPS input is correct; for parallel operation, the phase sequence of the live wires of UPS main and bypass circuit input and output is consistent.
10	Check the operating environment.	Remove electrical dust and other sundries inside and outside the cabinet.
11	Inspect whether the copper bars are short-circuited.	A multimeter shows the open circuit between the copper bars.

4 UPS Display Interface

4.1 Monitoring Display Unit

The monitoring display unit of UPS is located on the front panel of the UPS. Through the operation monitoring display unit, the operation control, parameter setting, operation status view, alarm view and other functions of UPS can be realized.

4.1.1 Panel Appearance

The appearance is shown in Fig. 4-1.

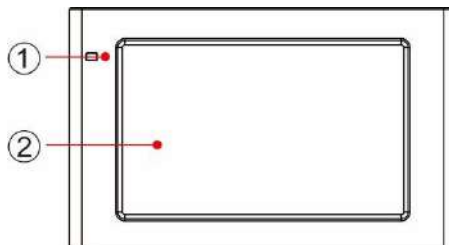

Fig. 4-1 Schematic diagram for panel of monitoring display unit

- 1 LED indicator light
- 2 LCD touch screen

4.1.2 LCD and Indicator Lights

The monitoring display unit can display various operation information and alarm information of UPS in real time through LCD, and parameters of UPS can be set and managed through LCD.

The status of indicator lights for monitoring display unit is shown in Table 4-1.

Table 4-1 Status of indicator lights

Indicator light	Color	Status	Description
Indicator light	Red	Lit	UPS failed
	Red	Flickered	UPS alarming
	Green	Lit	Power supply mode (mains mode, bypass mode, ECO mode, etc.)
	No	Gone out	Not started or in standby status

4.2 Display Interface

4.2.1 Overview

Menu structure

The menu structure of the monitoring display interface is shown in Fig. 4-2.

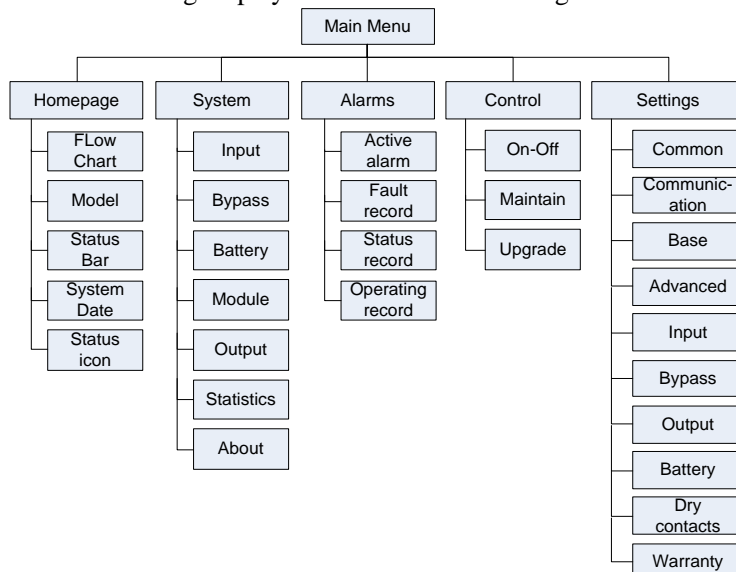

Fig. 4-2 Menu

Starting for the first time

Quick Settings can be set when the device is switched on for the first time or the device is switched on again after the factory settings are restored, as shown in Fig. 4-3. Specific quick settings interface includes language settings, display settings, system settings 1 and system settings 2, and you can directly skip the quick settings. Please refer to “4.2.6 Settings” for instructions and suggestions on setting items.

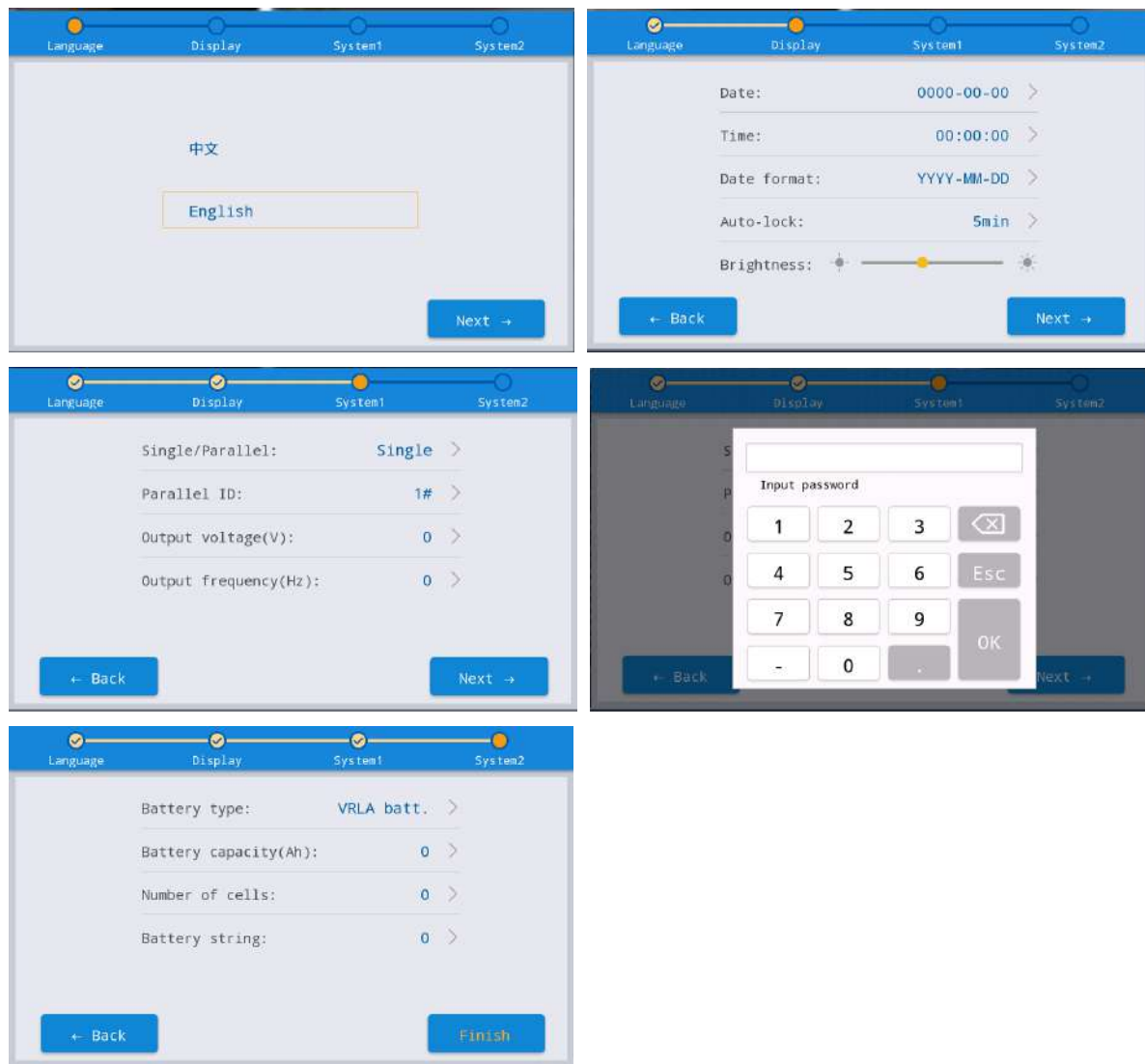

Fig. 4-3 quick settings

The home page is displayed after the quick setting is completed. Advanced password is required to set in the “System 1” settings and “System 2” settings in the quick settings.

4.2.2 Home Page

The home page is divided into three parts, including main menu, energy flow diagram, status bar. The home page is shown in Fig. 4-4:

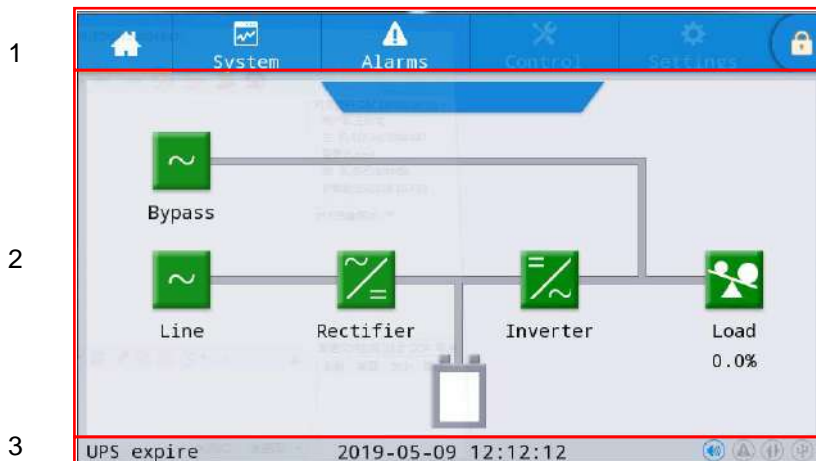

Fig. 4-4 Home page

Table 4-2 Function description of interface area

No.	Area	Function description
1	Main menu	Level 1 menu, including home page, system, alarm, control, settings, password login. The control and the settings are displayed in gray before login by password.
2	Energy flow diagram	Display the energy flow state of the cabinet. Click the corresponding work interface to view the status information.
3	Status bar	Display operation status, system time, buzzer status, alarm status, HMI and monitoring communication status, USB status of the cabinet.

Table 4-3 Description of icons in status bar

Icon	Function description
	Buzzer status, which becomes lit to indicate the buzzer enabled, and off to indicate the buzzer disabled
	Alarm status, which becomes lit to indicate an alarm, and off to indicate no alarm
	HMI communication status which becomes lit to indicate normal communication between HMI and monitoring module, and off to indicate abnormal communication between HMI and monitoring module
	USB connection status, which becomes lit to indicate normal connection of USB device, and off to indicate no connection or abnormal connection of USB device
	Password login/logout key. After clicking, enter user password or advanced password by the keyboard. The screen will be locked automatically.

Table 4-4 Description of password permissions

Password permissions	Default	Function description
User password	123456	Unlock On and OFF control right and the right of common settings and communication settings. It can be changed in "settings - common settings - user password".
Advanced password	Not opened	Unlock all control and setting rights. It can be used by qualified electricians only.

4.2.3 System

In the "System" information interface, the "Input", "Bypass", "Battery", "Module", "Output", "Statistics" and "About" information of the system can be inquired in the secondary menu at the left side.

Input

The menu interface of the mains input is shown in Fig. 4-5, and displays information on three phases ABC from left to right. The interface description is shown in Table 4-5.



Fig. 4-5 Input interface

Table 4-5 Description of input interface

Display item	Description
Voltage (V)	Mains input phase voltage
Current (A)	Mains input phase current
Frequency (Hz)	Mains input frequency

Bypass

The menu interface of the bypass input is shown in Fig. 4-6, and the interface description is shown in Table 4-6.



Fig. 4-6 Bypass interface

Table 4-6 Description of bypass interface

Display item	Description
Voltage (V)	Bypass input phase voltage
Current (A)	Bypass input phase current
Frequency (Hz)	Bypass input frequency

Battery

The interface menu of battery input is shown in Fig. 4-7, and the interface description is shown in Table 4-7.



Fig. 4-7 Battery interface

Table 4-7 Description of battery interface

Display item	Description
Battery voltage (V)	Battery voltage
Battery Current (A)	Battery current
Battery status	Current battery status: idle, charge, discharge, all charge, floating charge, sleep
Remaining cap. (%)	Current remaining capacity of battery
Backup time (min)	Estimated discharge time of the battery at the current load
Temperature (°C)	Current operating temperature of battery (optional battery temperature sensor, display "NA" if not connected)
SOH (%)	Percentage of battery health status

Module

It displays the information of each built-in power module. The menu interface of the module is shown in Fig. 4-8, and the interface description is shown in Table 4-8.



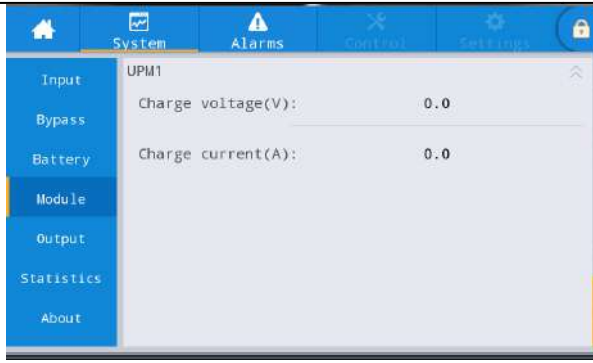

Fig. 4-8 Module interface

Table 4-8 Description of module interface

Display item	Description
Input volt. (V)	Input phase voltage of selected module
Input curr. (A)	Input phase current of selected module
Input freq. (Hz)	Input frequency of selected module
In.act. pow. (kW)	Input active power of selected module
In.appa. pow. (kVA)	Input apparent power of selected module
Input pow. factor	Ratio of the input active power to the input apparent power of selected module
Output volt. (V)	Output phase voltage of selected module
Output curr. (A)	Output phase current of selected module
Output freq. (Hz)	Output frequency of selected module
Out. act. pow. (kW)	Output active power of selected module
Out. appa. pow (kVA)	Output apparent power of selected module
Out. reac. pow (kVa)	Output reactive power of selected module
Out. pow. factor	Ratio of output active power to output apparent power of selected module
PFC power supply mode	Rectifier working mode: no power supply, mains power supply, battery power supply, combined power supply
OUT power supply mode	Output power supply mode: no output, inverter output, bypass output, Self-aging
Charge voltage (V)	Detected charging voltage of selected module
Charge current (A)	Detected charging current of selected module

Output

The interface of output menu is shown in Fig. 4-9, and the interface description is shown in Table 4-9.



Fig. 4-9 Output interface

Table 4-9 Description of output interface

Display item	Description
Voltage (V)	AC output phase voltage.
Current (A)	AC output phase current.
Frequency (Hz)	AC output frequency.
Load ratio (%)	Load rate of each phase of the machine, i.e. the ratio of actual power to rated power.
Active power (kW)	Output active power of each phase of the UPS unit
Appa. pow. (kVA)	Output apparent power of each phase of the UPS unit

Statistics

The interface of statistics menu is shown in Fig. 4-10, and the interface description is shown in Table 4-10.

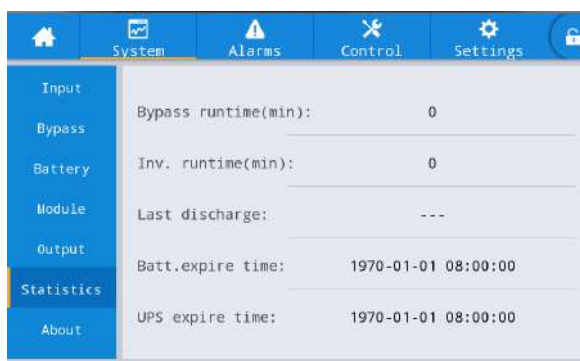

Fig. 4-10 Statistics interface

Table 4-10 Description of statistics interface

Display item	Description
Bypass runtime (min)	Accumulative operation time of UPS in bypass output status
Inv. Runtime (min)	Accumulative operation time of UPS in inverter output status
Last discharge	Date of previous discharge status of UPS
Batt. expire time	When the system time exceeds the warranty period, the status bar will prompt the warranty information of battery.
UPS expire time	When the system time exceeds the warranty period, the status bar will prompt the warranty information of main machine.

About

The interface of About menu is shown in Fig. 4-11, and the interface description is shown in Table 4-11.

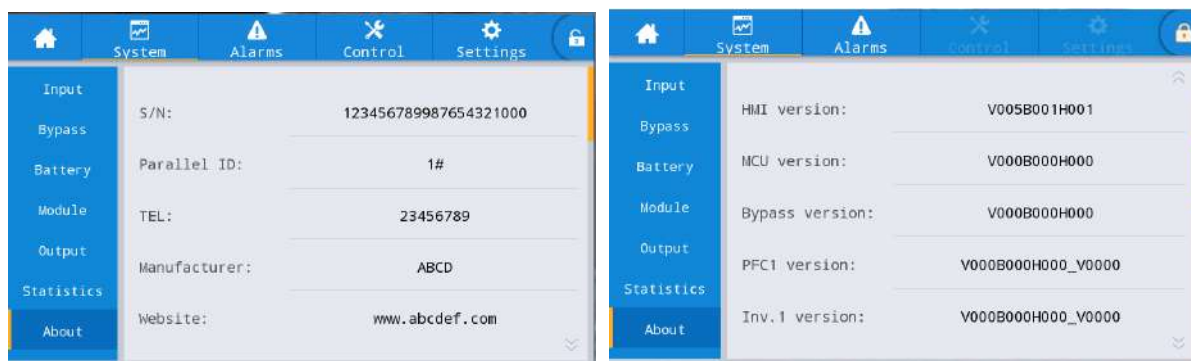

Fig. 4-11 About interface

Table 4-11 Description of Interface

Display item	Description
S/N	Production serial number of this machine.
Parallel ID	Used for distinguishing cabinet address in parallel system.
TEL	Contact information of after-sales service providers.
Manufacturer	Manufacturer of this machine.
Website	Website of manufacturer of this unit.
HMI version	Program version of HMI display system.
MCU version	Program version of monitoring system
Bypass version	Program version of power bypass system
PFC1 version	Program version of power rectifier system
Inv.1 version	Program version of power inverter system

4.2.4 Alarm

In the "Alarms" information interface, you can view "Active alarm", "Fault record", "Status record" and "Operating record" from the secondary menu in the lower left corner. The interface of alarm menu is shown in Fig. 4-12



Fig. 4-12 Alarm menu interface

Active alarm

The active alarm interface displays the relevant information of the current warning of UPS system, as shown in Fig. 4-13. The interface description is shown in Table 4-12.

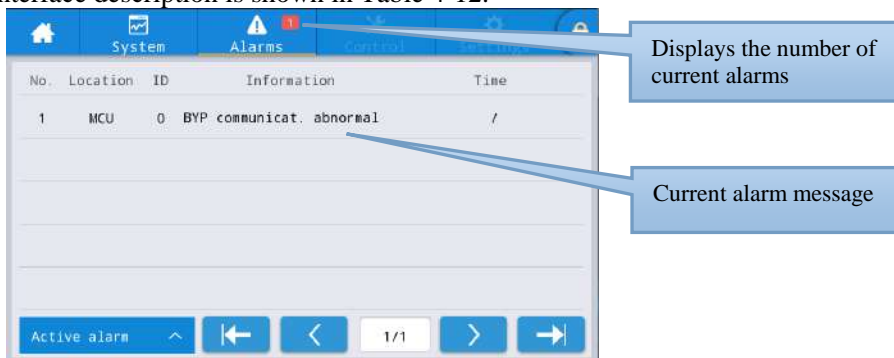

Fig. 4-13 Current alarm interface

Table 4-12 Description of active alarm interface

Display item	Description
No.	Alarm number
Location	Display the cabinet number and module number of the current alarm source.
ID	Alarm code for program analysis.
Information	Current alarm name
Time	The current alarm is the current alarm information without time display.

History records

The "history record" is divided into "Fault record", "Status record" and "Operating record". Take "Fault record" as an example, the history record interface is shown in Fig. 4-14, and the interface description is shown in Table 4-13.

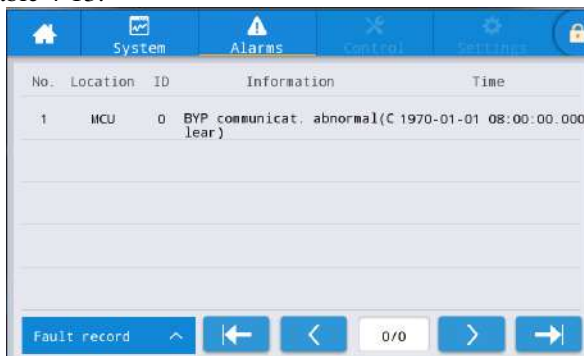

Fig. 4-14 History record interface

Table 4-13 Description of history record interface

Display item	Description
No.	Record number, which is listed in reverse order, that is to say the latest record is in the front.
Location	Displays the module number of the current record source.
ID	List code of fault, status or operation information for program analysis
Information	Current record name and record state (occurrence, disappearance).
Time	Record the time of occurrence or disappearance.

4.2.5 Control

In the "Control" information interface, you can select relevant operation from the left secondary menu, which contains "On-Off", "Maintain" and "Upgrade".

On-Off

The interface of the On-Off menu is shown in Fig. 4-15, and the interface description is shown in Table 4-14.

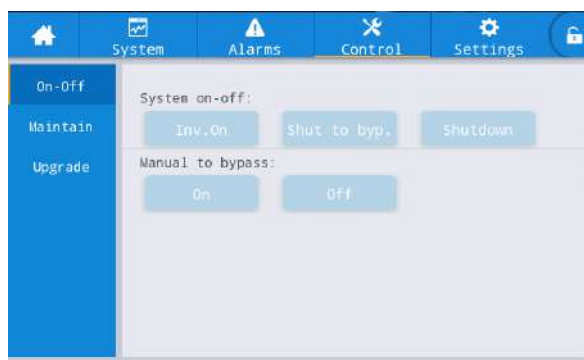

Fig. 4-15 On-Off interface

Table 4-14 Description of On-Off interface

Control item	Description
System on-off	Including "Inv.On", "Shut to bypass" and "Shutdown". It is gray when clicking is invalid.
Manual to bypass	Including "On" and "Off". It is gray when clicking is invalid. If the bypass is abnormal, switching to bypass fails.

Maintenance

The interface of maintenance menu is shown in Fig. 4-16, and the interface description is shown in Table 4-15.

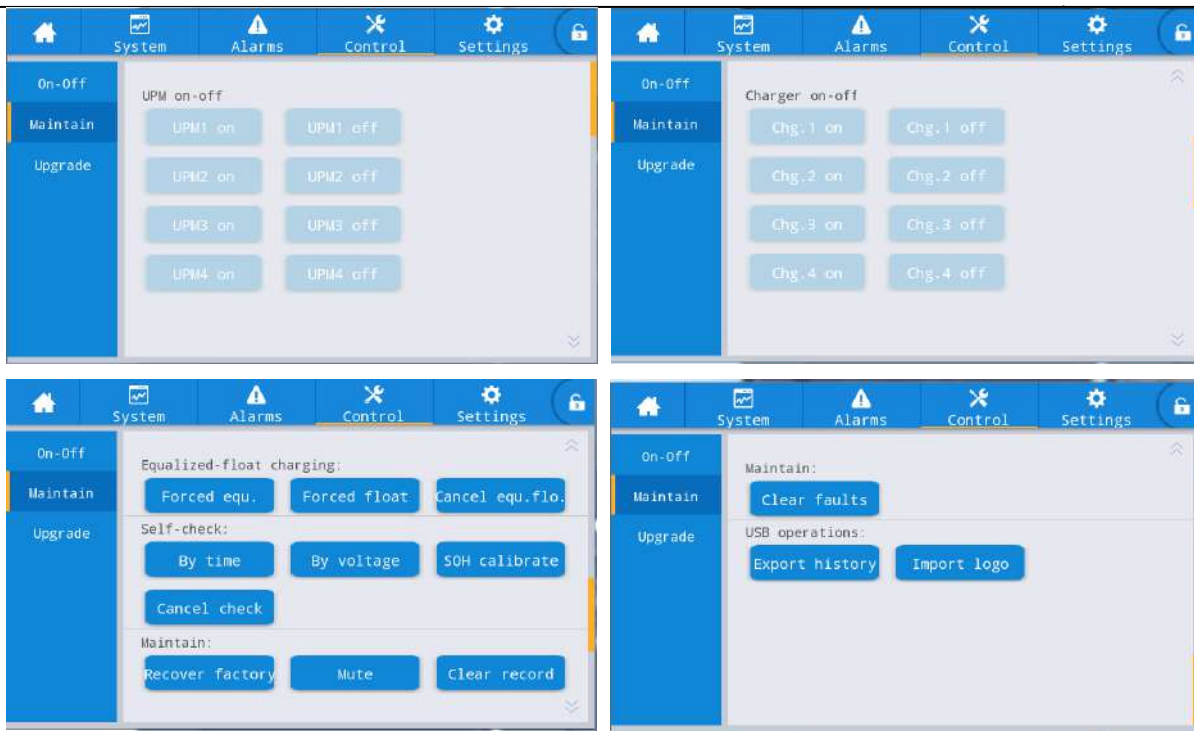

Fig. 4-16 Maintenance interface

Table 4-15 Description of maintenance interface

Control item	Description
Module On-off	Control ON/ Off of each online module.
Charger On-off	Control ON/ Off of online module charger.
Forced equalizing and floating charge control	Including forced equalizing charge, forced floating charge, canceling forced equalizing/floating charge which are used only when the battery is abnormal and make maintenance inspection.
Self-check control	Including self-test by time, self-test by voltage, SOH calibration and self-test cancellation.
Maintenance Management	Including factory reset, mute buzzer, clearing history records and clearing faults.
USB operations	Including exporting history records (export excel file) and importing LOGO (import boot animation).

Export history records

It is required to connect using a USB device, the exported history file is stored in the root directory. The information format of the exported history file is shown in Fig. 4-17, and the table description is shown in Table 4-16.

SN:9905019001f00							
MCU: V004	HMI: V005						
BYP: V105							
PFC1DSP: V204	PFC1CPLD:V1201	INV1DSP: V305	INV1CPLD:V1302				
PFC2DSP: V000	PFC2CPLD:V000	INV2DSP: V000	INV2CPLD:V000				
PFC3DSP: V000	PFC3CPLD:V000	INV3DSP: V000	INV3CPLD:V000				
PFC4DSP: V000	PFC4CPLD:V000	INV4DSP: V000	INV4CPLD:V000				
No.	Type	Source	ID	Event	Status	Value	Time
1	FLT		1016	Inverter	Active		0 2019-06-06 10:49:47:964

Fig. 4-17 Export file information of history records

Table 4-16 Table information description

Display item	Description
SN	Serial number of UPS
MCU	Program version of monitoring board
HMI	Program version of display board
PFC1DSP	Program version of rectifier 1 DSP
PFC1CPLD	Program version of rectifier 1 CPLD
INV1DSP	Program version of inverter 1 DSP
INV1CPLD	Program version of inverter 1 CPLD
No.	Record number
Type	Record type, including fault, status, operation
Source	Recording source
ID	Failure list code
Event	Record name
Status	Record status (occurrence/ disappearance)
Value	In the action record, displays the settings value of the item
Time	Record time of occurrence/ disappearance

Firmware upgrading

The interface of firmware upgrade menu is shown in Fig. 4-18, and the interface description is shown in Table 4-17.

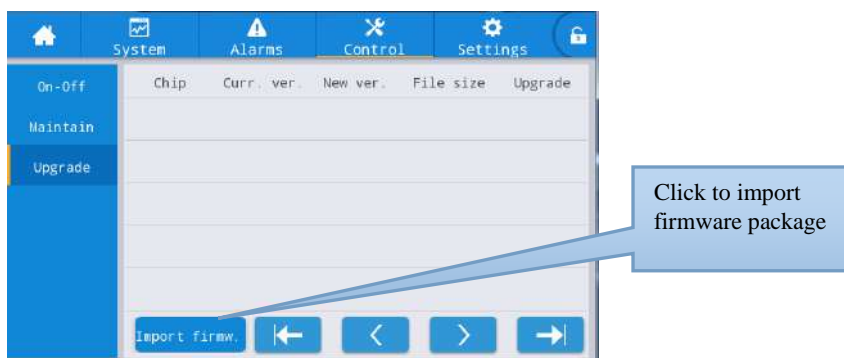

Fig. 4-18 Firmware upgrading interface

Table 4-17 Description of firmware upgrading interface

Display item	Description
Chip	Displays the name of the online chip.
Current version	Displays the current program version of the chip.
Version of new firmware	Version of chip program in the firmware package.
File length	File length of chip program in the firmware package.
Upgrade	When the chip program in the firmware package is verified successfully, the upgrade button will be displayed, and click it to upgrade; When file verification fails, the upgrade button is hidden and no upgrades will be allowed.

4.2.6 Settings

Common settings

The interface of common settings menu is shown in Fig. 4-19, and the interface description is shown in Table 4-18.

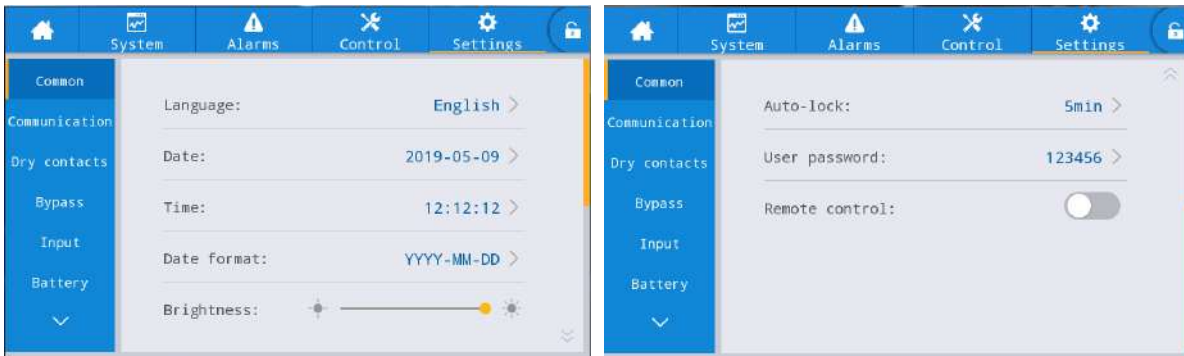

Fig. 4-19 Common setting interface

Table 4-18 Description of common setting interface

Setting item	Default	Options	Description
Language	English	English	Display in English.
YYYY-MM-DD	2016-01-01	2000-01-01~2099-12-31	Set the current date.
Time	00:00:00	00:00:00~23:59:59	Set the current time.
Date format	Y-M-D	Y-M-D, M-D-Y, D-M-Y	Support 3 formats: Y-M-D, M-D-Y, D-M-Y.
Brightness	100%	0% ~ 100%	Adjust backlight brightness by moving the slider.
Auto-lock	5 min	0 ~ 30 min	Set screen time out. 0 is set to keep the screen on.
User password	123456	0 ~ 99999999	The user can change the password, which can be set to 1-8 digits.
Remote control	Disabled	Enabled, disabled	For setting table for function code of user version MODBUS protocol 03; when enabled, remote setting is supported for the control items - "buzzer mute", "On-off" and "system clock"; Remote control is not supported when disabled.

Communication settings

The interface of the communication setting menu is shown in Fig. 4-20, and the interface description is shown in Table 4-19.



Fig. 4-20 Communication settings interface

Table 4-19 Description of communication settings interface

Setting item	Default	Options	Description
Protocol	MODBUS_U	MODBUS_U, R&D MODBUS, MEGATEC	Settings such as Protocol, Baud rate, Address and Parity are set for serial ports, including USB interface, RS232 interface and RS485 interface. Users can make the corresponding settings according to the setting requirements of the monitoring software used, but ensure that the setting value in the monitoring software must be consistent with the value in the UPS communication settings.
Baud rate	9600	2400, 4800, 9600, 14400, 19200, 38400	
Address	1	1 ~ 247	
Parity	None	None, Odd, Even	
IP address allocation	Auto (DHCP)	Auto (DHCP), Static	Settings such as IP address allocation, IP address, Subnet mask and Gateway are set for Ethernet port. When the UPS is connected to a router, it can be set to be dynamic and the router will automatically assign the address; When the UPS is connected to a computer directly, it needs to select static allocation, and set the IP address of the UPS and the IP address of the computer in the same network segment but different, and make the subnet mask and gateway information consistent.
IP address	0.0.0.0	0.0.0.0 ~ 255.255.255.255	
Subnet mask	0.0.0.0	0.0.0.0 ~ 255.255.255.255	
Gateway	0.0.0.0	0.0.0.0 ~ 255.255.255.255	

Dry contact settings

The interface of dry contact setting menu is shown in Fig. 4-21, and the interface description is shown in Table 4-20.

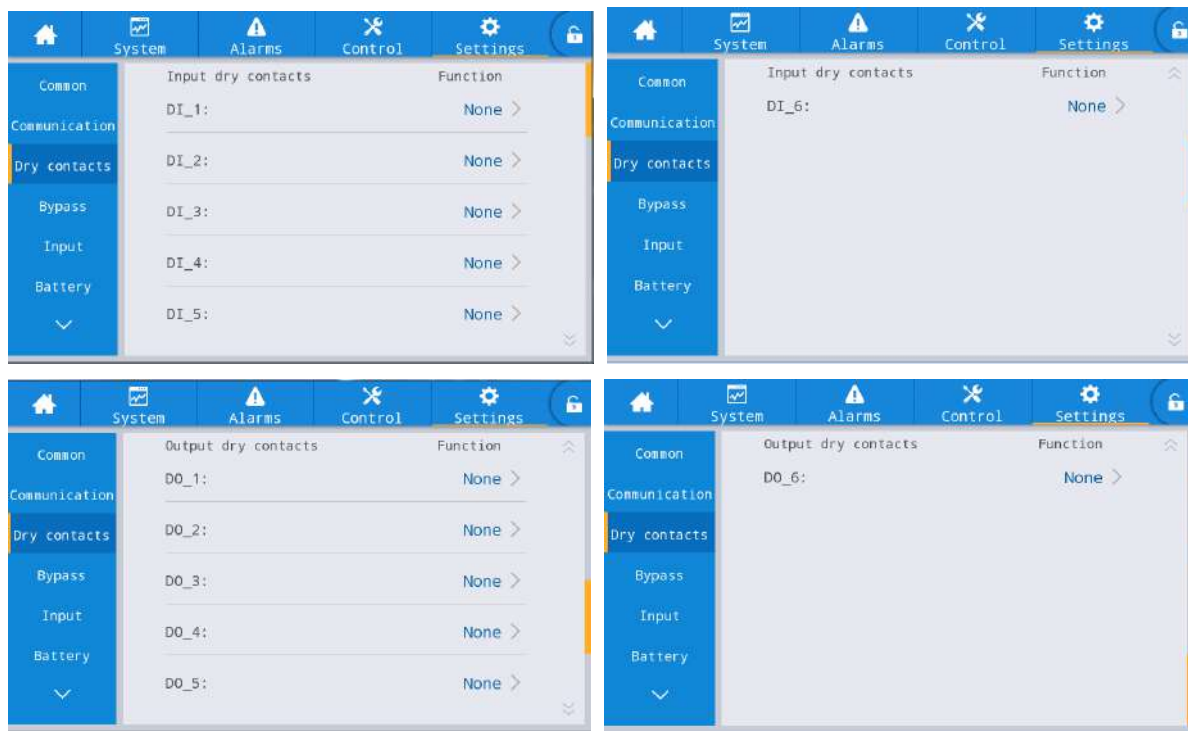

Fig. 4-21 Dry contact setting interface

Table 4-20 Description of dry contact setting interface

Setting item	Default	Options	Description
DI_1 ~ DI_6	None	None/Battery ground fault/D.G.mode/Battery breaker /PDC output breaker/ PDC mainten. Breaker/ PDC bypass breaker/AC SPD switch/ Ex.transfor.overtemp.	There are external 6 input dry contact interfaces. When configuring dry contacts, setting relevant dry contacts is required, and the unused dry contacts should be set to none, otherwise it will affect the normal operation of the UPS.
DO_1 ~ DO_6	None	None/Critical alarm/Minor alarm/Bypass power supply/Battery power supply/Low batt.volt.(DOD)/Low batt.volt.(EOD)/ D.G.control/Batt. breaker release/Bypass fault/Fan fault/Time-share power down	There are external 6 output dry contact interfaces. When configuring dry contacts, setting relevant dry contacts is required, and the unused dry contacts should be set to none, otherwise it will affect the normal operation of the UPS.

Bypass parameters

The interface of the bypass parameters menu is shown in Fig. 4-22, and the interface description is shown in Table 4-21.



Fig. 4-22 Bypass parameters interface

Table 4-21 Description of bypass parameters interface

Setting item	Default	Options	Description
ECO voltage range (%)	±10	±5/±6/±7/±8/±9/±10	When the deviation of the bypass voltage from the rated voltage exceeds the setting value, the system determines that the ECO voltage is abnormal, and it will switch to inverter to supply power. Note that the ECO frequency range cannot be greater than the bypass frequency range. For example, if the bypass frequency range is set to ±2 Hz, then the ECO frequency range can only be set to ±1 Hz and ±2 Hz.
ECO freq.range (Hz)	±2	±1/±2/±3	
Max.bypass voltage (%)	+15	+10/+15/+20/+25	The maximum setting range is 88 V to 276 V, which is generally within the acceptable voltage range of the user's electrical equipment.
Min.bypass voltage (%)	-20	-10/-20/-30/-40/-50/-60	
Bypass freq.range (Hz)	±5.0	±1.0/±2.0/±3.0/±4.0/±5.0/±6.0	Note that the bypass frequency range cannot be less than the ECO frequency range.

Input parameters

The interface of input parameters menu is shown in Fig. 4-23, and the interface description is shown in Table 4-22.

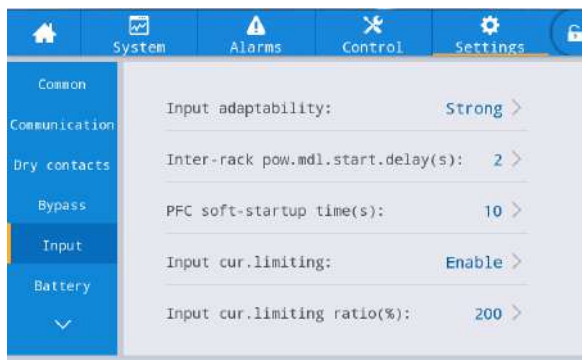

Fig. 4-23 Input parameters interface

Table 4-22 Description of input parameters interface

Setting item	Default	Options	Description
Input adaptability	Strong	Strong/Weak	The strong input adaptability mode applies to oil machine or input sources with high-frequency oscillation input current, and THDi in this mode is slightly worse, but the system is more stable. The weak input adaptability mode applies to input sources with better performance, such as mains power and AC voltage source, and THDi in this mode is better.
Inter-rack pow.mdl.start.delay (s)	2	2 ~ 120	In the process of battery inverter power being transferred to main circuit inverter power, control the interval time for each rack to be transferred to main circuit power in turn by setting the start delay of intelligent generator between racks, so as to reduce the impact of UPS on generator or power grid.
PFC soft-startup time (s)	10	0 ~ 60	
Input cur. limiting	Enable	Enable/Disable	According to the actual needs of users, set whether the UPS system controls the input current limit to protect the generator equipment.
Input cur.limiting ratio (%)	200	50 ~ 200	When the input current limit is selected as Enable, the current limit value of the main circuit input can be set. Its unit is the percentage of the rated input current, ranging from 50% to 200%, according to the output capacity of the generator equipment.

Battery parameters

The interface of battery parameters menu is shown in Fig. 4-24, and the interface description is shown in Table 4-23.

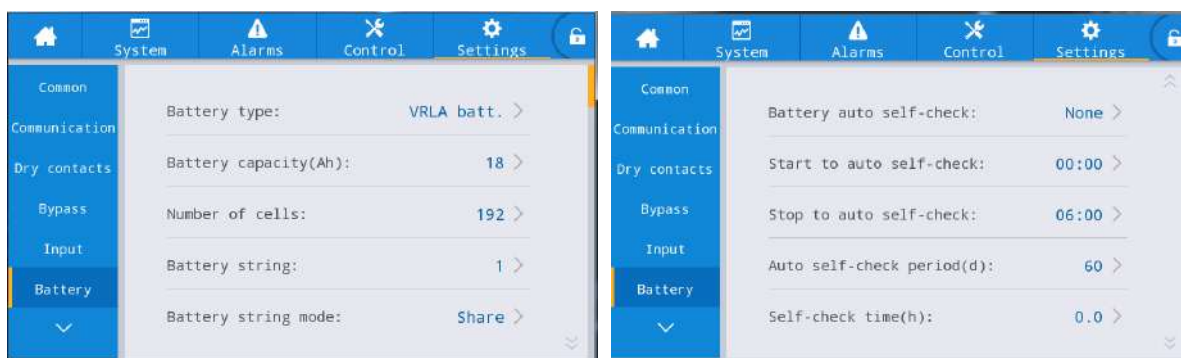

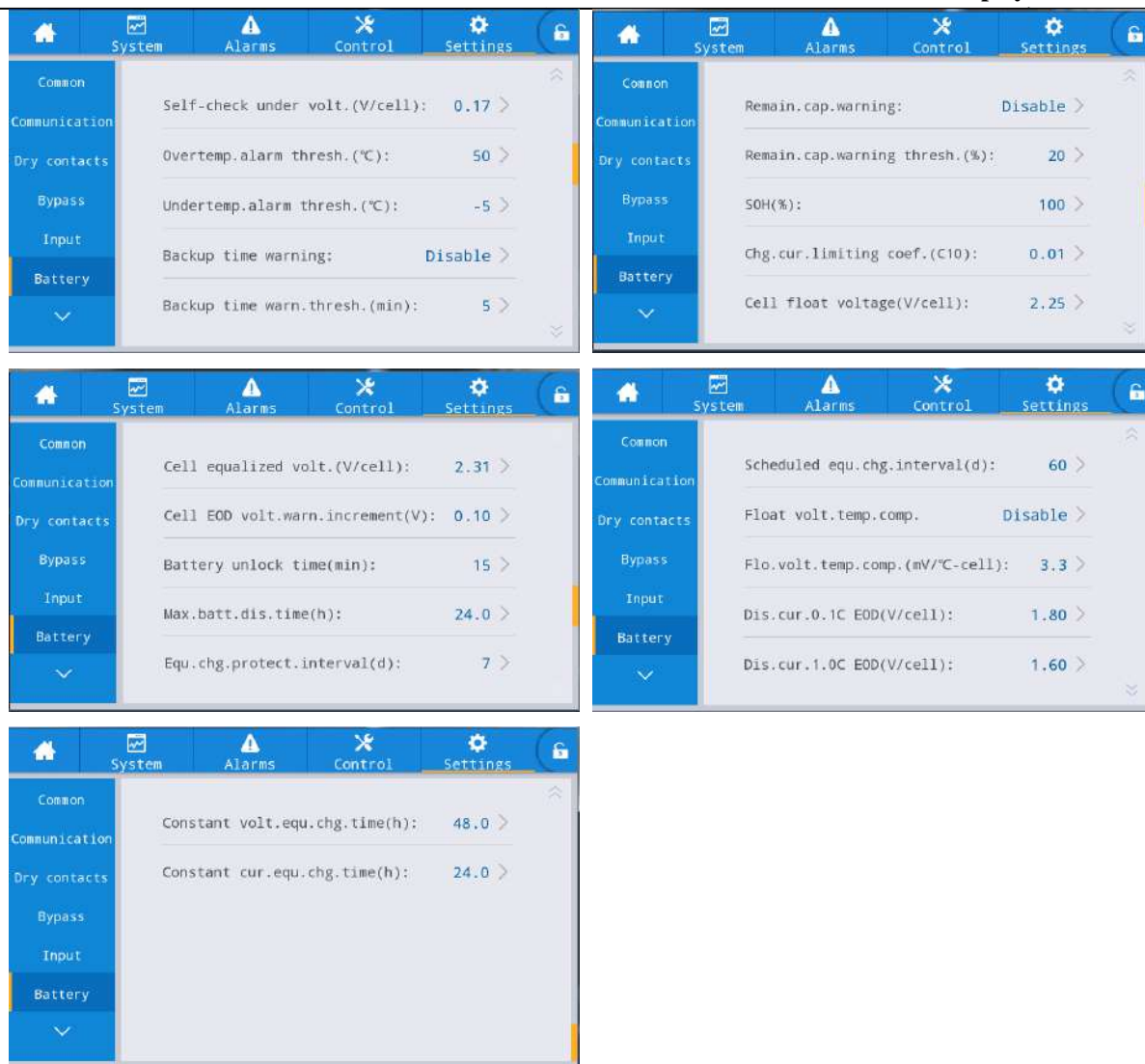

Fig. 4-24 Battery parameters interface

Table 4-23 Description of battery parameters interface

Setting item	Default	Options	Description
Battery type	VRLA batt.	VRLA batt./ Lithium batt.	Battery type connected to the UPS system. The supported lithium battery type is 3.2 V lithium iron phosphate battery.
Battery capacity (Ah)	18	5 ~ 3000	Single battery capacity connected to the UPS system
Number of cells	192	180 ~ 276	Set according to the total number of battery cells connected to the UPS system, each conventional lead-acid battery has 6 battery cells, for example, 32 batteries × 6=192 battery cells.
Battery string	1	1 ~ 10	Number of battery strings connected to the UPS system
Battery string mode	Share	Share/ Separate	Multiple UPSs connected in parallel can choose to share or not to share the same battery string.
Battery auto self-check	None	None/By time/ By volt.	When this function is enabled, the UPS system will automatically switch to battery mode to discharge according to relevant setting requirements.
Start to auto self-check	00:00	00:00 ~ 23:59	After <i>Battery auto self-check</i> being enabled, the UPS system will switch to the battery inverter mode at the configured time to start discharging and self-check.
Stop to auto self-check	06:00	00:00~23:59	After <i>Battery auto self-check</i> being enabled, the UPS system will switch from battery inverter to mains inverter at the configured time and end self-check.

Setting item	Default	Options	Description
Auto self-check period (d)	60	30 ~ 90	After <i>Battery auto self-check</i> being enabled, the UPS system will perform battery discharge and self-test within the configured time period based on configured number of days.
Self-check time (h)	0.0	0.0 ~ 23.0	After <i>Battery auto self-check</i> being enabled and selecting self-check by time, the UPS system will perform battery discharge and self-test within the configured time period, and exit until the duration of self-test reaches the configured time. Note that the configured self-test time should be within the configured period of auto self-check, otherwise the self-test will fail.
Self-check under volt. (V/cell)	1.70	1.60 ~ 1.90	After <i>Battery auto self-check</i> being enabled and selecting self-check by voltage, the UPS system will switch to the battery inverter mode to perform self-test, and exit the self-test until the battery cell voltage reaches the configured self-test end voltage, or exit the self-test when the configured self-test end time is reached.
Overtemp.alarm thresh. (°C)	50	45 ~ 55	The battery temperature can be monitored in time. When the battery temperature is detected to be higher than the high temperature alarm point or lower than the low temperature alarm point, the system will emit an alarm.
Undertemp.alarm thresh. (°C)	-5	-20 ~ 5	
Backup time warning	Disable	Disable/Enable	If this alarm function is enabled, the system will emit an alarm when the backup time reaches the configured value.
Backup time warn. thresh. (min)	5	3 ~ 30	
Remain. cap. warning	Disable	Disable/Enable	If the alarm function is enabled, the system will emit an alarm when the remaining capacity reaches the configured value.
Remain. cap. warning thresh. (%)	20	5 ~ 50	
SOH (%)	100	0 ~ 100	The ratio of actual battery capacity to nominal capacity after the battery being used for a period of time
Chg. cur. limiting coef. (C10)	0.10	0.05 ~ 0.15	The limit of charging current which users can set
Cell float voltage (V/cell)	2.25	2.23 ~ 2.27	Charging voltage of single cells under floating charge condition
Cell equalized volt. (V/cell)	2.31	2.30 ~ 2.40	Charging voltage of single cells under equalizing charge condition
Cell EOD volt. warn. increment (V)	0.10	0 ~ 0.20	Increase the value of this setting on the basis of the voltage of the single cells at the EOD point. If the voltage of the single cells reaches this value, the battery EOD pre-alarm will be emitted.
Battery unlock time (min)	15	1 ~ 60	If the switching times between the mains inverter and the battery inverter reaches 5 times within an hour, the UPS will be locked in the battery inverter state. The time required to unlock can be set through this option.
Max. batt. dis. Time (h)	24.0	0 ~ 48.0	It is the maximum time of continuous discharge under the condition of battery discharge. When the discharge time reaches this value, the system will switch to bypass if the bypass is normal, and the system will be powered off and shut down if the bypass is abnormal.

Setting item	Default	Options	Description
Equ. chg. protect. Interval (d)	7	0 ~ 15	If the batteries are not discharged after last time normal equalizing charge ending and being transferred to floating charge, it is the time interval required for the system to perform equalizing charge of the battery.
Scheduled equ. chg. interval (d)	60	30 ~ 180	When the equalizing charge process ends and the duration reaches the timed equalizing charge interval, the system will automatically perform equalizing charge of the battery.
Float volt. temp. comp.	Disable	Disable/Enable	If this function is enabled, the system can automatically perform temperature compensation and correction for the floating charge voltage according to the battery temperature, and the reference temperature value of the temperature compensation is 25 °C.
Flo. volt. temp. comp. (mV/°C-cell)	3.3	0 ~ 6.0	
Dis. cur. 0.1C EOD (V/cell)	1.80	1.75 ~ 1.90	It is the voltage of the single cells at the EOD point when the discharge current is 0.1 C.
Dis. cur. 1.0C EOD (V/cell)	1.60	1.60 ~ 1.75	It is the voltage of the single cells at the EOD point when the discharge current is 1.0 C.
Constant volt. equ. chg. time (h)	48.0	0 ~ 100.0	It is duration of constant voltage equalizing charge when the battery is in the equalizing charge stage.
Constant cur. equ. chg. time (h)	24.0	0 ~ 100.0	It is duration of constant current equalizing charge when the battery is in the equalizing charge stage.

Output parameters

The interface of output parameters menu is shown in Fig. 4-25, and the interface description is shown in Table 4-24.

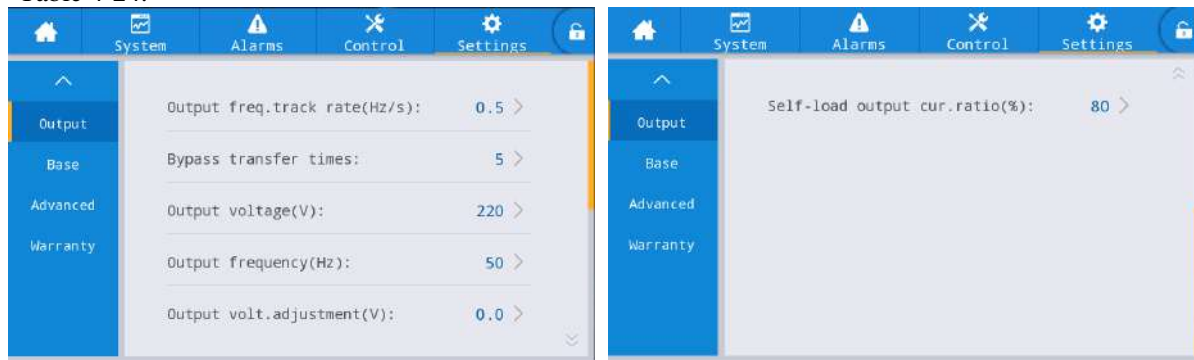

Fig. 4-25 Output parameters interface

Table 4-24 Description of output parameters interface

Setting item	Default	Options	Description
Output freq. track rate (Hz/s)	0.5	0.1 ~ 2.0	Set according to the load capacity. If the tracking rate is too slow, when the bypass frequency changes, it will lead to the inverter working frequency and the bypass frequency in an asynchronous state.
Bypass transfer times	5	1 ~ 10	1 ~ 10 times is optional. 5 times is default. If the bypass switching times reach the configured value within one hour, the system will be locked. If it is in normal mode, the system will be locked at the bypass end supplying power; if it is in ECO mode, it will be locked at the inverter end supplying power.

Setting item	Default	Options	Description
Output voltage (V)	220	220/230/240	The user sets it according to the output voltage amplitude acceptable by the load, which should be set in the state of no output.
Output frequency (Hz)	50	50/60	The user sets it according to the output voltage frequency acceptable by the load, which should be set in the state of shutdown.
Output volt. adjustment (V)	0.0	-5.0 ~ 5.0	Fine tune the output voltage according to the customer's field power distribution.
Self-load output cur. ratio (%)	80	20 ~ 100	It is percentage of output current in rated output current in self-aging mode.

Basic parameters

The interface of basic parameters menu is shown in Fig. 4-26, and the interface description is shown in Table 4-25.



Fig. 4-26 Basic parameters interface

Table 4-25 Description of basic parameters interface

Setting item	Default	Options	Description
Single/Parallel	Single	Single/Parallel	Set according to the actual number of online frames in the system. Select <i>Single</i> when only 1 frame works. Select <i>Parallel</i> when at least 2 frames work.
Parallel ID	1#	1 ~ 4	Each single unit needs to be numbered in parallel system, and their numbers cannot be same.
Advanced password	/	0 ~ 99999999	Only authorized qualified electricians can use and change the password, which can be set to 1-8 digits, and cannot be same with the user password. Customers who need to know the password should consult the supplier.
Settings wizard	Enabled	Enabled/Disabled	After being enabled, the UPS will enter the quick settings interface at next time when turn on it.
Set language limit	Disabled	Enabled/Disabled	After being enabled, language is limited to English, and cannot be set anymore.

Advanced parameters

The interface of advanced parameters menu is shown in Fig. 4-27, and the interface description is shown in Table 4-26.

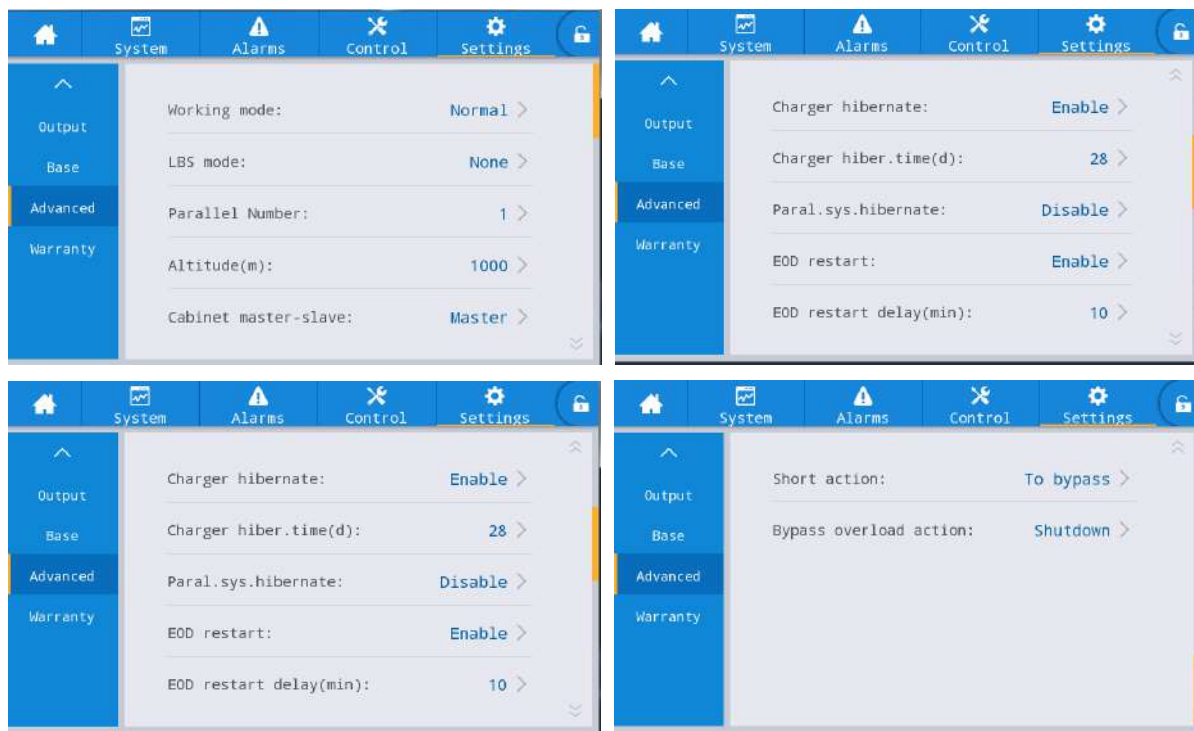

Fig. 4-27 Advanced parameters interface

Table 4-26 Description of advanced parameters interface

Setting item	Default	Options	Description
Working mode	Normal	Normal/ECO/Self-load /Converter	Select the corresponding working mode according to user needs. It is normal working mode in general.
LBS mode	None	None/Master/Slave	If uses need to use double bus system, it can be set according to the actual situation.
Parallel Number	1	1 ~ 4	Set according to the actual frame numbers of the UPS system installed by the user.
Altitude (m)	1000	0 ~ 3000	Set according to the actual situation on site. The output capacity will be automatically derated according to the setting value. For details, please refer to the derating description in the table “8 Technical parameters” .
Cabinet master-slave	Master	Master/Slave	This setting item does not need to be set. It will be automatically allocated by the parallel system.
Charger hibernate	Enable	Enable/Disable	If set it to be enabled, the charger will enter the hibernation state when it meets the hibernation condition. If set to be disabled, the charger will not enter the hibernation state
Charger hiber. time (d)	28	28 ~ 60	When <i>Charger hibernate</i> function is set to be enabled, after the charger enters the hibernation state, it will exit from it if the configured time is reached.

Setting item	Default	Options	Description
Paral. sys. hibernate	Disable	Disable/Enable	Set <i>Paral. sys. hibernate</i> according to system configuration and user needs, so that the parallel system can automatically determine the numbers of UPSs or modules to be put into operation according to the current total loads. Under the condition of ensuring redundant power supply, the spare UPS can be quit and put into hibernation state for the purpose of safe operation and energy saving.
EOD restart	Enable	Enable/Disable	In the mode of abnormal mains power switching to battery power, when the UPS is turned off due to low battery (EOD), and the whole system cannot be powered by the bypass and power off, the system will automatically restart if this setting is enabled when the mains power is restored; If this setting is disabled, the user needs to manually turn on the UPS after the fault is cleared manually or change <i>EOD restart</i> setting to be enabled.
EOD restart delay (min)	10	1 ~ 1440	When setting the <i>EOD restart</i> to be enabled, after the system EOD power off and the power supply is restored, delay the configured time and the system will automatically start the inverter output.
Forced bypass	Disabled	Disabled/ Enabled	If set it to be enabled, when the UPS system needs to switch to the bypass output power supply, even if the bypass voltage is abnormal, the UPS system will still switch to the bypass mode. When the bypass is ultra-high voltage, the UPS system cannot switch to the bypass mode to supply power.
Impact to bypass	Enabled	Enabled/Disabled	If set it to be enabled, the system will switch to the bypass mode to supply power for a while when the impact load make the output voltage of the UPS system drop rapidly.
EPO function	Enabled	Enable/Disabled	Set whether to enable EPO function according to the actual needs of users.
EPO action	To bypass	To bypass, Shutdown	According to the actual needs of users, set the corresponding action of the UPS system which is to switch to the bypass or cut off the output when the EPO alarm is triggered. Select <i>Shutdown</i> in general.
Maint.conver plate	Enabled	Enabled/Disabled	If set it to be enabled, the system will test the installation status of maintenance cover plate.
Short action	To bypass	To bypass, Shutdown	When an output short circuit occurs in the UPS system, the UPS system will switch to bypass or cut off the output.
Bypass overload action	Shutdown	Shutdown, None	According to the actual needs of users, when the bypass overload time arrives, the UPS system will continue operating with loads in the bypass mode or cut off the output.

Warranty expiration settings

The interface of the warranty expiration settings menu is shown in Fig. 4-28, and the interface description is shown in Table 4-27.

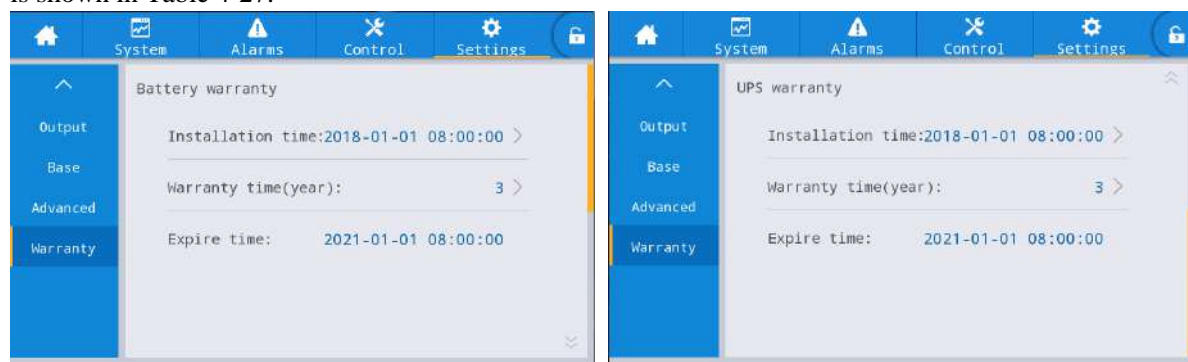

Fig. 4-28 Warranty expiration settings interface

Table 4-27 Description of warranty expiration settings interface

Setting item	Default	Options	Description
Battery Installation time	2018-01-01 00:00:00	Any value	Click the popup box to confirm the update to the current time.
Battery Warranty time (year)	3	1 ~ 50	Set according to the actual battery warranty time for the users.
Battery Expire time	2021-01-01 00:00:00	Not settable	The warranty expiration time is automatically generated according to installation time and warranty time. When the system time exceeds the warranty period, the status bar of home page will prompt the warranty information.
UPS Installation time	2018-01-01 00:00:00	Any value	Click the popup box to confirm the update to the current time.
UPS Warranty time (year)	3	1 ~ 50	Set according to the actual UPS warranty time for the users.
UPS Expire time	2021-01-01 00:00:00	Not settable	The warranty expiration time is automatically generated according to installation time and warranty time. When the system time exceeds the warranty period, the status bar of home page will prompt the warranty information.

5 Operation

5.1 Operation of Single UPS System

5.1.1 Turn On the UPS

	CAUTION
	<ul style="list-style-type: none"> • Check whether all screws are tightened and all wiring is correct before turning on the UPS. • Disconnect the mains input circuit breaker, bypass input breaker, output breaker and battery breaker. • According to load requirement, make sure to set “<i>Output voltage(V)</i>” and “<i>Output frequency(Hz)</i>” properly in the “<i>Settings</i>” interface before starting up. • For long time model UPS, make sure to set “<i>Battery type</i>”, “<i>Battery capacity(Ah)</i>”, “<i>Number of cells</i>” and “<i>Battery string</i>” in the battery parameters interface before starting up. Ensure that configured parameters must be matched with the connected battery string.

Operation procedures:

Step 1: Close the external input distribution switch (mains input breaker and bypass input breaker) to power on the system while the system will start initialization, the company’s LOGO and initialization progress bar will be displayed on the monitor screen. In this case, the system is in standby mode.

Step 2: After the monitoring is started normally, if the equipment is powered on for the first time, the relevant parameters can be set through quick setting guidelines; when powering on again, the system defaults to the previous setting. If these parameters are already set, the system defaults to the existing settings. Please refer to the quick settings in 4.2.1 for specific operation interface.

Step 3: After the quick settings is completed, if there is no abnormal alarm on the display interface, continue to perform the following steps; If there is an abnormal alarm on the display interface (at this time, because the battery has not been connected, it is a normal alarm to report "battery not connected"), reset all abnormal alarms.

Step 4: Start the inverter.

If “*Control*” is gray and not selectable on the main menu of the monitoring display unit, unlocking is required first. Click the password lock in the upper right corner of the display interface while the system will pop up the unlocking window, and enter the password, as shown in Fig. 5-1.

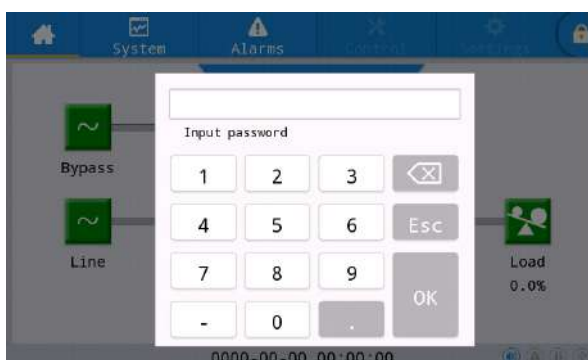

Fig. 5-1 Unlocking window

Select “*Control*” in the main menu of the monitoring display unit, click “*Inv.On*”, and complete the inverter starting operation after selecting “*OK*”, as shown in Fig. 5-2.

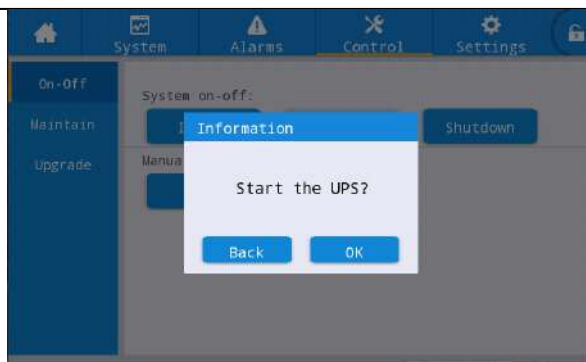

Fig. 5-2 Startup

Step 5: After the inverter startup, UPS switches to the inverter power supply, and the system operation status diagram can be checked to confirm whether the system is powered by the main inverter.

View and confirmation of monitoring display interface

The real-time data displayed “System” → “Output” in the display interface can be used to confirm whether the three-phase output voltage and frequency of UPS are normal, and a multimeter can be used to test whether the effective value and frequency of the three-phase output voltage are normal, as shown in Fig. 5-3.

Input	Voltage(V):	219.9	219.9	220.0
Bypass	Current(A):	4.4	4.3	8.5
Battery	Frequency(Hz):	49.98	49.98	49.98
Module	Load ratio(%):	7.2	7.2	14.1
Output	Active power(kW):	0.9	0.9	1.8
Statistics				
About				

Fig. 5-3 Output information

Step 6: Check whether the actual number of battery strings is consistent with the number of single batteries set on the monitoring display interface; measure by the multimeter whether the absolute value of the positive battery voltage and the negative battery voltage are greater than a certain value (for 12V battery, $11.4v \times \text{number of batteries}$), to prove the normal connection of the battery. After confirming the connection of the battery string, close the input breaker of the battery strings (if there are multiple batteries, close the breaker of each battery string first, and then close the master switch between the battery string and UPS). The batteries self-check to confirm whether the battery works normally.

Step 7: Close the external output distribution switch to supply power to the load.

Note

If the UPS has been powered on or is in the bypass power supply mode, and it is required to change to the inverter power supply mode, just confirm that there is no abnormal alarm at present and then execute step 4; if UPS is fully powered off, complete all of the above steps.

5.1.2 Turn Off the UPS

	CAUTION
	<ul style="list-style-type: none"> • When “Shut to bypass” is selected, if the system bypass is normal, after UPS inverter is powered off, the system will enter the bypass power supply mode; if the system bypass is abnormal, the inverter will be shut down and the system will enter no-output mode. • When “Shutdown” is selected, the system directly enters the no-output mode after the inverter is powered off, and the system output is closed. • Before shutdown, please confirm that the user’s equipment (i.e., UPS load) has been shut down and can withstand power failure at any time.

Operation procedures:

Step 1: Turn off the inverter.

If “Control” is gray and not selectable on the main menu of the monitoring display unit, unlocking is required first. Click the password lock in the upper right corner of the display interface while the system will pop up the unlocking window, and enter the password, as shown in Fig. 5-1.

Select “Control” in the main menu of the display unit, click “Shut to bypass”, and after selection and confirmation, complete the operation of turning off the inverter, as shown in Fig. 5-4.

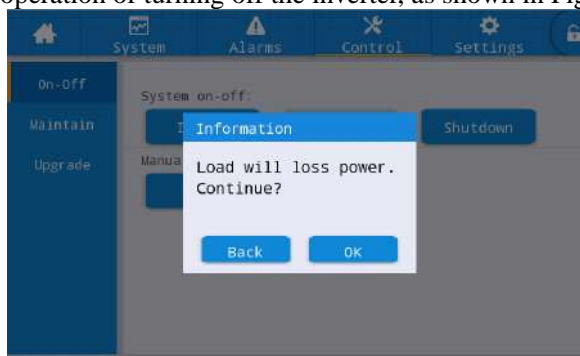

Fig. 5-4 Turn off inverter

Step 2: After the inverter is powered off, if the system bypass is normal, UPS enters the bypass power supply mode. If the system bypass is abnormal, UPS will enter no-output mode after inverter is powered off, resulting in power failure of load.

Step 3: After the inverter is powered off, power off the external output distribution switch.

Step 4: Disconnect the breaker of the battery string (if there are multiple batteries, first disconnect the master switch between the battery strings and UPS, then disconnect the breaker of each battery string).

Step 5: Disconnect the external mains input distribution switch and the bypass input distribution switch.

Note

If it is only required to power off the UPS inverter and supply the power by the system bypass, after confirming that UPS has no abnormal alarm at present, it is only required to execute step 1; if it required to fully power off UPS, all of the above steps should be performed.

5.1.3 Battery Cold Start

Operation procedures:

Step 1: Confirm that the battery is connected properly, and measure by the multimeter whether the absolute value of the positive battery voltage and the negative battery voltage are greater than a certain value (for 12V battery, $11.4 \text{ V} \times \text{number of batteries}$).

Step 2: Disconnect the input breaker of the external mains circuit and bypass, and close the battery breaker in case of no input of the mains and the bypass (if there are multiple batteries, close the breaker of each battery string first, and then close the master switch between the battery string and UPS).

Step 3: Measure the voltage of the positive and negative battery strings connected to the input terminal of UPS battery by the multimeter. If the absolute value of the positive battery string voltage and negative battery string voltage is greater than a certain value (for 12V battery, $11.4 \text{ V} \times \text{number of batteries}$), the battery is connected normally.

Step 4: Press the battery cold start button on the equipment for more than 3 seconds. The position of the battery cold start button is shown in Fig. 2-8 or Fig. 2-11. The system will automatically enter the battery cold start state while both the company's LOGO and the initialization bar are displayed on in the monitoring display unit.

Step 5: After the initialization of the monitoring display unit is completed, refer to Step 3, Step 5 and Step 6 in “5.1.1 Turn On the UPS” to turn on the inverter.

5.1.4 Transfer to Bypass Operation by Manual

	CAUTION
	<ul style="list-style-type: none"> • Before manual change to bypass, confirm that the bypass is normal. If the bypass is abnormal, manual change to bypass will be invalid and the previous state will be retained. • In the bypass power supply mode, when the input voltage or frequency range exceeds the setting value of the system, it is possible to cause no output of the system and power failure of the load.

Operation procedures:

If "Control" is gray and not selectable on the main menu of the monitoring display unit, unlocking is required first. Click the password lock in the upper right corner of the display interface while the system will pop up the unlocking window, and enter the password, as shown in Fig. 5-1.

Select "Control" on the main menu of the monitoring display unit, click "Manual to bypass", and after selection and confirmation, complete "Manual to bypass" Power Supply Mode, as shown Fig. 5-5.

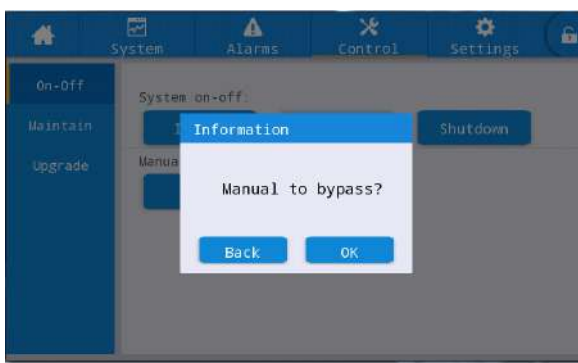



Fig. 5-5 Manual to bypass

5.1.5 Transfer to Maintenance Bypass

	CAUTION
	<ul style="list-style-type: none"> • Transferring to maintenance bypass operation must be performed in strict accordance with the following steps, otherwise it is possible to cause the power failure of the load. • In the maintenance bypass mode, the load is powered from mains supply via the maintenance bypass. If the mains supply is abnormal, the load may be cut off.

Step 1: Refer to the operation steps in 5.1.4, manually transfer UPS to the bypass power supply mode.

Step 2: First remove fasteners of the maintenance bypass breaker, and then close the maintenance bypass breaker. Manually close the UPS maintenance bypass breaker. The UPS system switches to the maintenance bypass mode; the maintenance bypass breaker defaults to in "OFF" state, and manually switch it to the "ON" state, at which time the maintenance bypass breaker is closed. At the same time, the monitoring display interface displays "Maintenance bypass breaker connected" alarm.

5.1.6 Power Supply Restored from Maintenance Bypass to Inverter

	CAUTION
	<p>Before recovery of power supply from maintenance bypass to inverter, confirm that the bypass input and output of the system are normal.</p>

Operation procedures:

Step 1: Manually switch the maintenance bypass breaker from "ON" state to "OFF" state while the maintenance bypass breaker is disconnected and the "Maintenance bypass breaker connected" alarm disappears on the monitoring alarm interface. At this time, the system operation status diagram can be viewed in the monitoring display interface to confirm whether the system is in bypass power supply mode.

Step 2: Start the UPS inverter, referring to Step 2 ~ Step 6 in "5.1.1 Turn On the UPS".

5.1.7 Emergency Power Off (EPO)

	CAUTION
	<ul style="list-style-type: none"> • By default, the operation of EPO will not cause the UPS output power to turn off, and make the UPS switch to bypass output to prevent accidental power outages. If the UPS is required to have no output directly, need to set “EPO action” as “Shutdown”. • After pressing the "EPO" button, it may cause no output for the UPS and power failure for the loads..

Operation procedures:

Unplug the dry contact connector at the normally closed end interface of EPO or close the external EPO switch connected with the dry contact while UPS will enter the state of emergency shutdown. At this time, the monitoring display screen gives an alarm.

5.1.8 EPO Recovery

Operation procedures:

Step 1: Plug in the dry contact connector at the normally closed interface of EPO or disconnect the EPO switch connected with the dry contact, and confirm that the EPO switch connected with the dry contact is not in the emergency shutdown state.

Step 2: Clear EPO alarm in the system.

Select “Control” → “maintain” → “Clear fault” in the main menu of the monitoring display unit, and select "OK" in the popup prompt dialog to clear the EPO alarm, as shown in figure 5-6.

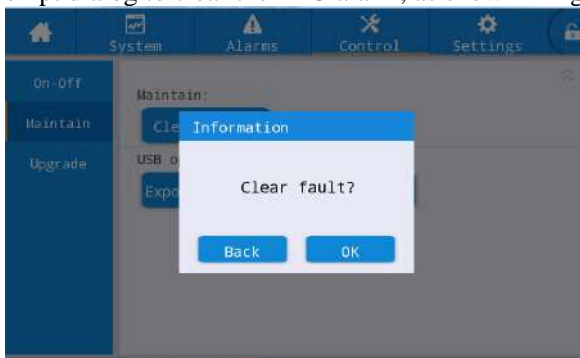



Fig. 5-6 Fault clearance

Step 3: check the current alarm and confirm that the "EPO" alarm disappears. If the system bypass input is normal, UPS will switch to the bypass power supply mode.

Step 4: Turn on the inverter, referring to “5.1.1 Turn On the UPS”.

5.1.9 Firmware Upgrade

	CAUTION
	<ul style="list-style-type: none"> • During firmware upgrade operation, it may switch to the maintenance bypass mode to supply power. It may result in power failure of the load when mains power is abnormal. • USB flash disk and firmware upgrade program are required for the upgrade operation. Please prepare them in advance.

Upgrade of monitoring and main control firmware

Operation procedures:

Step 1: Put the firmware package in the fixed path of USB flash disk, such as U:\Update\EA900.img.

Step 2: Switch the working unit to the maintenance bypass power mode, refer to 5.1.5, or switch to standby mode which does not need power output.

Step 3: Insert the USB flash disk into the USB interface of the monitoring board and wait for the USB icon in the lower right corner of the home page becoming lit.

Step 4: Click the unlock icon and enter the advanced password.

Step 5: Access “Control” → “Upgrade” interface, click “Import firmw.”, and wait unit it is imported successfully after confirmation.

Step 6: Check whether the chip, current version and new firmware version are correct.

Step 7: Click the upgrade button on the right side of one of the chips to upgrade the corresponding module. During upgrading, after the corresponding chip is restarted automatically and displayed, and then the next chip may be upgraded. Complete the upgrade in sequence.

Step 8: After upgrading of monitoring firmware, the monitor will be restarted automatically. It is required to exit the firmware upgrading page manually while all firmware information is displayed.

Step 9: Restore power supply from the maintenance bypass to the inverter and start the UPS inverter, refer to Step 2 ~ Step 6 in “5.1.1 Turn On the UPS”.

Upgrading of display screen HMI firmware

Operation procedures:

Step 1: Put the firmware package in the root directory of USB flash disk, such as U: \ITEPKG03.PKG.

Step 2: Insert the USB flash disk into the USB interface of the monitoring board and wait for the USB icon in the lower right corner of the home page becoming lit.

Step 3: Click the reset button on the back panel of the display screen to restart the display screen.

Step 4: Check whether burning progress in percentage is displayed on the display screen, and if yes, wait for the completion of burning. If no, the firmware reading fails or the USB flash disk identification fails, please check whether the firmware is put into the USB flash disk correctly or replace other normal USB flash disks and try again.

Step 5: When burning completed is displayed (i.e. "IMFO: Upgrade finished"), pull out the USB flash disk and click the reset button on the back panel of the display screen to restart the display screen or power on again.

Step 6: Access “System → “About” in the display page to check whether the "HMI version" has been updated successfully.

5.2 Operation of Parallel UPS System

5.2.1 Start Up Parallel System

	Important
	<ul style="list-style-type: none"> • Ensure that all switches on the UPS are disconnected before wiring and installation. • Before starting, check whether the wiring of the parallel system is correct and fully connected, all screws are tightened.

Operation procedures:

Step 1: Building of Parallel UPS system

For the parallel UPS system, please refer to “3.3 Installation of Parallel UPS System” to connect the power cables and control cables. If the batteries are independent, they can be wired separately.

Step 2: Wiring confirmation

Use a multimeter to reconfirm that all wiring is correct.

Step 3: Single unit commissioning

After wiring properly, ensure that all the mains input circuit breakers, bypass input breakers, output breakers and battery breakers of all UPS units are disconnected and the system output breaker is disconnected as well, then debug in turn the single unit which needs to be connected in parallel, confirm that the single unit is normal, record its output voltage, confirm and turn off the UPS, disconnect all the input, output, battery and bypass breakers of single units. Please refer to “5.1 Operation of Single UPS System” for the debugging process.

Step 4: Check the output voltage of each single unit

After debugging each single unit and confirming their parameters, restart them and compare the output voltage of each UPS, confirm that the effective value difference of phase voltage corresponding to the three phases of any two UPSs is less than 2 V, then they can be connected in parallel. If the condition is not met, UPSs with large voltage deviation cannot be connected in the parallel system, fine tune the output voltage of them are required. For UPSs with large deviation, sampling and calibration should be performed again to ensure that the effective value difference of phase voltage corresponding to the three phases of other UPSs is less than 2V.

Step 5: Confirm software version

Ensure that all the bypass breakers, output breakers and battery breakers of all UPS units are disconnected, and close the input breakers of all UPS units, then verify the program version of the UPS which needs to be connected in parallel. Enter the “About” interface in the system menu, verify the “HMI version”, “MCU version”, “Bypass version”, “PFC1 version” and “Inv.1 version”, and ensure that the program version of each part is consistent.

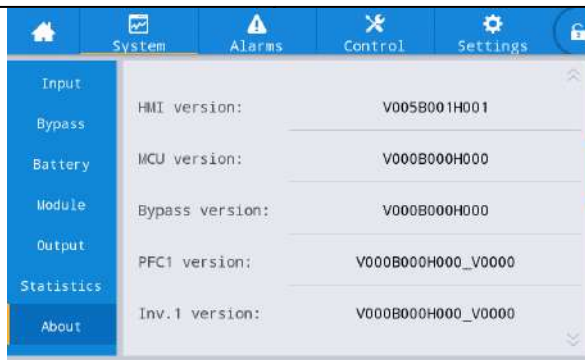

Fig. 5-7 About interface

Step 6: Confirm parameters

For single UPS units which need to be connected in parallel, their advanced parameters, input parameters, output parameters, bypass parameters and battery parameters (Be consistent when “*Battery string mode*” is set as “*Share*”, and specific settings are performed according to the battery configuration of each unit when it is set as “*Separate*”) in the setting interface should be kept consistent. Please refer to “**4.2.6 Settings**” for parameters settings

Step 7: Check phase sequence of the bypass (Each UPS output breaker is disconnected, and the system output breaker is disconnected)

Turn on each unit and switch them to bypass mode, close the output breaker of UPS 1# (ensure that the master switch for loads is disconnected, otherwise UPS 1# will supply power to loads after its output breaker being closed) and keep output breakers of other UPSs disconnected. Make a multimeter on AC voltage, a pen connected to the A phase at front end of the output breaker of UPS 2#, and the other pen connected to the A phase at back end of the output breaker of UPS 2#, measure the voltage difference between front and back end of the output breaker of UPS 2#, and measure B and C phase in the same way. If the phase sequence is correct, the voltage difference of each phase is less than 5 V; If the phase sequence is incorrect, at least one phase voltage difference is more than 5 V. Use same method to test whether the bypass phase sequence of each UPS which needs to be connected in parallel is correct (when testing the phase sequence of other UPSs, there is no need to operate breakers again. Keep the output breaker of UPS 1# closed while output breakers of other UPSs are disconnected). If the bypass phase sequence of all UPSs are correct, proceed to the next step; If there is phase sequence incorrect from any one of UPS, need to power down the system and check whether the bypass input/output wiring of each UPS is correct or not. After confirmation, turn off each UPS and cut off the output.

Step 8: Set parallel parameters (All UPS units are in the shutdown and no output state)

1. In the “*Settings*” interface → “*Base*” → “*Single/Parallel*” option, set as “*parallel*”
2. In the “*Settings*” interface → “*Base*” → “*Parallel ID*” option, set as “1#”, “2#”, “3#”, “4#” in turn. Support maximum 4 units in parallel.



Fig. 5-8 Parallel parameters settings

Step 9: Confirm parallel signal

After setting as “*parallel*”, if the parallel communication cable is not connected, it will report the fault of “*Parallel line abnormal*”. It is necessary to confirm that no such fault occurs on each UPS in parallel system. If the fault is reported again, need to check whether the parallel communication cables are connected properly or not.

Step 10: Start up parallel system

Confirm that the system only operates on the main circuit and the bypass, and close the output breakers of all UPS units, and then directly click “*Inv.On*”. The startup operation is consistent with the startup operation of the single UPS (only need to operate any one of parallel UPS units).

Step 11: Add battery strings

View monitoring and confirm that each UPS unit has switched to the inverter mode. After the system output is normal, add battery strings and close the battery breaker. If the parallel UPS system uses separated battery strings, close the battery breaker of each UPS unit separately. "Battery disconnected" of each UPS unit disappears within 3 min after closing. Make sure the batteries are connected properly.

Step 12: Switching test

Disconnect the master input breaker and confirm that all UPS units switch to battery mode normally, which can be observed through monitoring.

Close the input breaker, then manually turn off the UPS unit which switches to bypass, and then check whether all the UPS units switch to the bypass mode normally, which can be observed through monitoring.

Step 13: Close the output breaker of the system

After the system switching to bypass, close the system output breaker, make the bypass carry with loads, then turn on the UPS which switches to the inverter mode normally, so the whole parallel system startup process is completed.

5.2.2 Shut Down Parallel System

Operation procedures:

Step 1: Turn off all loads

Step 2: Select any one of UPS units to perform "shutdown" operation in the "On-Off" interface through monitoring. The system will automatically synchronize this operation to the whole system.

Step 3: After doing step 2 for about 5 min, disconnect the system output breaker, output breakers of each UPS, battery breakers, bypass input breaker and mains input circuit in turn, so the parallel system shutdown is completed.

5.2.3 EPO

The EPO function of a single UPS in the parallel system is not available temporarily. As long as the EPO of one UPS unit is enabled, the system will automatically synchronize to all UPS units in the whole system.

5.2.4 Single UPS Unit Exit the Parallel System

Operation procedures:

Step 1: After failure of a single UPS, its output will be cut off automatically, and it will exit from the parallel system. The system will be continuously powered by other UPSs.

Step 2: Disconnect the output breaker on the output distribution cabinet of the failed UPS or the external output distribution breaker.

Step 3: Disconnect the battery breaker of the failed UPS (if there are multiple battery strings, disconnect the master switch between battery strings and the UPS first, then disconnect each battery breaker) or the front-end distribution switch.

Step 4: Disconnect the mains input and bypass input breakers on the input distribution cabinet of the failed UPS or the front-end distribution switch.

Step 5: The failed UPS is isolated from the system and can perform other maintenance operations.

5.2.5 Add a Single UPS to the Parallel System

Operation procedures:

Step 1: After maintenance of the single UPS is completed, disconnect the parallel cables before power on. The "Single/Parallel" option in the "Base" parameters setting interface is set as "Single".

Step 2: Power on to make sampling correction and single unit commissioning again, ensure that the output breaker is disconnected during this process. For the single unit commissioning operation, please refer to "5.1 Operation of Single UPS System".

Step 3: Confirm in turn: check the output voltage, software version, parameters, bypass phase sequence of the single UPS. The specific procedures are the same as those in Step 4 to 7 in 5.2.1.

Step 4: Reconnect the parallel cables, set parallel parameters and confirm the parallel signal. Refer to Step 9 and Step 10 in 5.2.1.

Step 5: Switch the parallel system without adding the maintained single UPS to bypass mode manually, close all switches of the newly added UPS, and then start up the system.

6 Maintenance

6.1 UPS Maintenance

6.1.1 Monthly Maintenance

- Check the operating conditions of the equipment, including ambient temperature, humidity, input/output voltage, frequency, load type, load rate, various alarm information, etc.
- Check UPS for abnormal sound. If there is any abnormal sound, continue to check for the source of abnormal sound, mainly including fan, input/output transformer (skip if not configured), power unit and bypass unit. If the cause is not identified, contact the supplier in time.
- Check whether the input and output terminals of the equipment are firm, the connecting cables are intact, aged or damaged. If damaged, analyze reasons for the damage, and pay special attention to rat control.
- Check the UPS monitoring panel, and confirm that all graphic display units on the monitoring panel are in normal operation status, and all operating parameters of the power supply are within the normal range, and no failure or alarm information is found in the display record.
- Dust and clean the equipment if needed.
- Check whether there is any change in the load carried by UPS and periodically check and record the increase and decrease of load.
- Check and record the operating environment temperature and humidity of UPS.
- Check whether the parameter configuration of UPS is correct.
- Fill in UPS maintenance report form, sort and treat abnormal situation and alarm.
- Export and analyze alarm information from the system, and output the alarm analysis report.

6.1.2 Quarterly Maintenance

Repeat monthly inspection.

- Conduct a thorough dust removal and cleaning for UPS, paying special attention to the cleaning of dust accumulating at fans and inlet and outlet.
- Inspect whether input/output cables and terminals are aged, damaged, burned and loose, and reinforce all input/output terminals.
- If conditions permit, it is necessary to inspect key internal components of UPS, mainly including the following components:
 - Electrolytic capacitor: check for leakage, roof caving and expansion.
 - Transformers and inductors: check for overheating, discoloration and delamination.
 - Cable and cable arrangement: check whether sheath of the connecting cable is damaged, cracked and scraped, reinforce all power cable connection terminals, and check whether the cables are firmly installed between boards.
 - Fuses: check that all fuses are in good condition and installed securely.
 - Printed circuit board: check the cleanliness of printed circuit board and the integrity of the circuit, pay attention to check whether there is overheating, discoloration, the circuit board components are intact without damage and corrosion.
- If there is an input/output transformer, check whether the transformer has overheating, discoloration, delamination and falling off, prevent turn-to-turn short circuit, and check whether the connection terminal is firm, rusted or corroded.
- Check by the multimeter and the clip-on ammeter whether input, output, battery, load voltage and current are consistent with those required by system requirements and displayed in the LCD display.

6.1.3 Annual Maintenance

Repeat all quarterly maintenance and inspections.

In order to prevent system failure resulting from the working wear and tear of components, it is recommended to regularly inspect the key components used in the UPS system, and replace them within their expected life span. The life parameters and recommended replacement time of key devices are shown in Table 6-1.

Table 6-1 Recommended replacement time of key devices

Key components	Recommended replacement period	Recommended inspection period
Electrolytic capacitor	5 - 6 years	One year
Fan	5 - 6 years	One year
Lead-acid battery	3 - 4 years	6 months

6.2 Battery Maintenance

The following battery maintenance considerations are only maintenance recommendations for a general lead acid battery. Please refer to the battery maintenance instructions shipped with the battery for details.

CAUTION	
	<ul style="list-style-type: none"> • Battery replacement and maintenance shall only be performed by authorized qualified personnel. • During the battery maintenance, it is required to insulate the tool (wrench, etc.) first. • Disconnect all power supply before connecting or disconnecting the terminals. • Do not smoke or use open fire near the battery string. • Fully charge the battery within 24h after discharging, so as not to affect the battery life. • In case of no power failure in a power grid environment for a long time, the battery should be discharged every 3 to 6 months and then recharged to extend the battery life. • Regularly measure the voltage of the battery string and each single battery to ensure the voltage balance of each single battery. If the voltage of the single is too low, replace the corresponding battery.

7 Troubleshooting

Use the table below to solve minor installation and operation problems.

No.	Problems	Possible cause	Solution
1	Rectifier starting failed	Input AC voltage out of standard	Verify that the input distribution voltage is abnormal
		Abnormal phase sequence of UPS three phase input	Check whether the phase sequence of UPS three-phase input is correct.
		Power unit failed	Replace the power unit
2	Inverter failure, UPS changing to bypass power supply mode	Output overload or short circuit protection	Reduce load or remove load short circuit fault
		UPS overheating protection	Install air conditioning or ventilation facilities in the machine room to ensure the normal temperature of the machine room
		Power unit failed	Replace the power unit
3	DC system abnormal and failure to operate normally in battery mode	Battery undervoltage or failed	Replace the battery
		Failure to connect the battery cable as required, or poor contact of wiring terminals or battery breaker not closed	Eliminate battery wiring problems and make sure the battery breaker closed
		Power unit failed	Replace the power unit
4	System works in the bypass and failing to change to the invert mode	Set to ECO mode	Set the correct working mode
		Bypasses switching times reaches maximum	Set the appropriate bypass switching times in the setting interface; or clear the fault in the control interface
		Inverter failed	Refer to above No. 2
5	Indicator light of power unit illuminates red	Abnormal AC input and battery input	Confirm whether the input cables and cables are loose and the distribution is abnormal
		Power unit failed	Replace the power unit

Note

- If components replacement is required for the above troubleshooting and involved in Appendix C alarm list, please consult with the supplier.

8 Technical Parameters

Mode	40 kVA	60 kVA	80 kVA	120 kVA
Rated capacity	40 kVA/40 kW	60 kVA/60 kW	80 kVA/80 kW	120 kVA/120 kW
Input				
Input wiring	Three-phase five line (3 Φ + N + PE)			
Rated voltage	380Vac/400Vac/415Vac (line voltage)			
Voltage range	304 Vac ~ 485 Vac (no downgrading) 138 Vac ~ 304 Vac (linear downgrading at 40% ~ 100% load)			
Frequency range	40 ~ 70 Hz			
Power factor	≥ 0.99 @100% resistive load, ≥ 0.97 @50% resistive load			
Total harmonic of input current (THDi)	$\leq 3\%$ @100% resistive load, $\leq 5\%$ @50% resistive load			
Bypass input voltage range	380 Vac: -20% ~ +15% (upper limit +10%/+15%/+20%/+25% settable) 400 Vac: -20% ~ +15% (upper limit +10%/+15%/+20% settable) 415 Vac: -20% ~ +10% (upper limit +10%/+15% settable) (lower limit -60%/-50%/-40%/-30%/-20%/-10% settable)			
Bypass frequency range	± 5 Hz (± 1 Hz/ ± 2 Hz/ ± 3 Hz/ ± 4 Hz/ ± 5 Hz/ ± 6 Hz settable)			
ECO voltage range	$\pm 10\%$ ($\pm 5\%$ / $\pm 6\%$ / $\pm 7\%$ / $\pm 8\%$ / $\pm 9\%$ / $\pm 10\%$ settable)			
ECO frequency range	± 2 Hz (± 1 Hz/ ± 2 Hz/ ± 3 Hz settable)			
Output				
Output wiring	Three-phase five line (3 Φ + N + PE)			
Rated voltage	380 Vac/400 Vac/415 Vac $\pm 1\%$ (line voltage)			
Output frequency	Mains mode: tracking bypass input in synchronous state; Battery mode or frequency conversion mode or beyond the frequency tracking range: 50 Hz/60 Hz $\pm 0.1\%$			
Power factor	1			
Output waveform distortion (THDv)	$\leq 1\%$ @100% resistive load			
Output voltage imbalance	$\leq 3\%$			
Output voltage phase deviation	$\leq 1^\circ$			
Crest factor	3:1			
Switching time	Mains mode - battery mode: 0 ms; Inverter mode - bypass mode (synchronous switching): 0 ms; Inverter mode -ECO mode (synchronous switching): 0 ms;			
Inverter overload capability	105% < load 110%, switching to bypass in 60 minutes; 110% < load 125%, switching to bypass in 10 minutes; 125% < load 150%, switching to bypass in 1 minute; Load > 150%, switching to bypass in 0.2 seconds			
Battery				
Battery type	Lead-acid battery			
Battery voltage	360 Vdc ~ 552 Vdc (30 ~ 46 pcs selectable, 32 pcs by default)			
Equalizing charge voltage	2.31 V/Cell (settable to 2.30 ~ 2.40 V/Cell)			
Floating charge voltage	2.25 V/Cell (settable to 2.23 ~ 2.27 V/Cell)			
Maximum charging current	12 A	24 A	24 A	36 A
Charging temperature compensation	-3 mV/°C for T $\geq 25^\circ\text{C}$ (-1 ~ -8 mV/°C settable), 0 mV per °C for T < 25 °C			
System				

Mode	40 kVA	60 kVA	80 kVA	120 kVA
Display	5.0 inch touch color screen			
Protections	Output short circuit protection, output overload protection, over-temperature protection, low battery protection, output over/under-voltage protection, fan fault protection, etc			
Max. number of parallel connections	4			
Environmental				
Operating temperature	0 ~ 40°C			
Storage temperature	-25 ~ 55°C (without battery)			
Humidity	0 ~ 95% (non-condensing)			
Altitude	≤ 1000 m; for above 1000 m, downgrading 1% for each additional 100 m; Max. 5000 m; 0 ~ 5000 m settable			
IP rating	IP 20			
Noise	≤ 65 dB (at 1 m)			
Communication				
Communication interface	Standard: RS232, RS485, USB, CAN, NET, EPO, LBS, parallel, input/output dry contacts, dual smart card slot, 1-way battery temperature sampling interface; Optional: SNMP card, GPRS card, Wi-Fi card, battery temperature sensor, parallel cable, etc.			
Physical				
Wiring mode	Bottom cable entry			
Dimensions (W × D × H) (mm)	360 × 850 × 950		360 × 850 × 1200	440 × 850 × 1200
Net weight (kg)	93	122	157	192

Appendix 1 Display Menu

Level 1 menu	Level 2 menu	Level 3 menu	Level 4 menu
Homepage			
System	Input	Voltage(V)	
		Current(A)	
		Frequency(Hz)	
	Bypass	Voltage(V)	
		Current(A)	
		Frequency(Hz)	
	Battery	Battery voltage(V)	
		Battery Current(A)	
		Battery status	
		Temperature(°C)	
		SOH(%)	
		Remaining cap.(%)	
	Module (#)	Input volt.(V)	
		Input curr.(A)	
		Input freq.(Hz)	
		In.act.pow.(kVA)	
		In.appa.pow.(kVA)	
		Input pow.factor	
		Output volt.(V)	
		Output curr.(A)	
		Output freq.(Hz)	
		Out.act.pow.(kW)	
		Out.appa.pow(kVA)	
		Out.reac.pow(kVa)	
		Out.pow.factor	
		PFC power supply mode	
		OUT power supply mode	
		Charge voltage(V)	
		Charge current(A)	
		Output	Voltage(V)
Current(A)			
Frequency(Hz)			
Load ratio(%)			
Active power(kW)			
Appa. pow.(kVA)			
Statistics	Bypass runtime(min)		
	Inv. runtime(min)		
	Last discharge		
	UPS expire time		
About	S/N		

Level 1 menu	Level 2 menu	Level 3 menu	Level 4 menu	
		Parallel ID		
		TEL		
		Manufacturer		
		Website		
		HMI version		
		MCU version		
		Bypass version		
		PFC1 version		
		Inv.1 version		
Alarms	Active alarm			
	Fault record			
	Status record			
	Operating record			
Control	On-Off	System on-off	Inv.On	
			Shut to bypass	Shutdown
		Manual to bypass	On	Off
	Maintain	UPM on-off	UPM1 on	UPM1 off
			UPM2 on	UPM2 off
			UPM3 on	UPM3 off
			UPM4 on	UPM4 off
		Charger on-off	Chg.1 on	Chg.1 off
			Chg.2 on	Chg.2 off
			Chg.3 on	Chg.3 off
			Chg.4 on	Chg.4 off
		Equalized-float charging	Forced equ.	Forced float
			Cancel equ.flo.	
		Self-check	By time	By voltage
			SOH calibrate	Cancel check
		Maintain	Recover factory	Mute
			Clear record	Clear faults
		USB operations	Export history	Import logo
	Upgrade	Import firmw.		
Settings	Common	Language		
		YYYY-MM-DD		
		Time		
		Date format		
		Brightness		
		Auto-lock		
		User password		
		Remote control		

Level 1 menu	Level 2 menu	Level 3 menu	Level 4 menu		
	Communication	Serial port	Protocol	Baud rate	
		Network	Address	Parity	
			I IP address allocation	IP address	
			Subnet mask	Gateway	
	Dry contacts	Input dry contacts	DI_1	DI_2	
			DI_3	DI_4	
			DI_5	DI_6	
		Output dry contacts	DO_1	DO_2	
			DO_3	DO_4	
			DO_5	DO_6	
	Bypass	ECO voltage range (%)			
		ECO freq.range (Hz)			
		Max.bypass voltage (%)			
		Min.bypass voltage (%)			
		Bypass freq.range (Hz)			
Input	Input adaptability				
	Inter-rack pow.mdl.start.delay (s)				
	PFC soft-startup time (s)				
	Input cur. limiting				
	Input cur.limiting ratio (%)				
Battery	Battery type				
	Battery capacity (Ah)				
	Number of cells				
	Battery string				
	Battery string mode				
	Battery auto self-check				
	Start to auto self-check				
	Stop to auto self-check				
	Auto self-check period (d)				
	Self-check time (h)				
	Self-check under volt. (V/cell)				
	Overtemp.alarm thresh. (°C)				
	Undertemp.alarm thresh. (°C)				
	Backup time warning				
	Backup time warn. thresh. (min)				
	Remain. cap. warning				
	Remain. cap. warning thresh. (%)				
	SOH (%)				
	Chg. cur. limiting coef. (C10)				
	Cell float voltage (V/cell)				
	Cell equalized volt. (V/cell)				
Cell EOD volt. warn. increment (V)					

Level 1 menu	Level 2 menu	Level 3 menu	Level 4 menu		
		Battery unlock time (min)			
		Max. batt. dis. Time (h)			
		Equ. chg. protect. Interval (d)			
		Scheduled equ. chg. interval (d)			
		Float volt. temp. comp.			
		Flo. volt. temp. comp. (mV/°C-cell)			
		Dis. cur. 0.1C EOD (V/cell)			
		Dis. cur. 1.0C EOD (V/cell)			
		Constant volt. equ. chg. time (h)			
		Constant cur. equ. chg. time (h)			
		Output	Output freq. track rate (Hz/s)		
			Bypass transfer times		
	Output voltage (V)				
	Output frequency (Hz)				
	Output volt. adjustment (V)				
	Self-load output cur. ratio (%)				
	Base	Single/Parallel			
		Parallel ID			
		Advanced password			
		Settings wizard			
		Set language limit			
	Advanced	Working mode			
		LBS mode			
		Parallel Number			
		Altitude (m)			
Cabinet master-slave					
Charger hibernate					
Charger hiber. time (d)					
Paral. sys. hibernate					
EOD restart					
EOD restart delay (min)					
Forced bypass					
Impact to bypass					
EPO function					
EPO action					
Maint.conver plate					
Short action					
Bypass overload action					
Warranty		Battery warranty	Installation time	Warranty time(year)	
	Expire time				
	UPS warranty	Installation time	Warranty time(year)		
		Expire time			

Appendix 2 Alarm List

Alarm code	Alarm description	Cause	Corrective action
100-102	Input overvoltage	Abnormally high input voltage	Check the mains input voltage
103-104	Input undervoltage	Abnormally low input voltage	Check the mains input voltage
106	Input over-frequency	Abnormal input frequency	Check the mains input frequency
107	Input under-voltage	Abnormal input frequency	Check the mains input frequency
108	Input phase sequence reversed	Input phase sequence reversed	Check mains input cables
109	Input voltage unbalanced	Input voltage unbalanced	Check the mains input voltage
110	Input current unbalanced	Input current unbalanced	Replace the power unit or the module
124	Input phase loss	Input phase loss	Check the mains input voltage
125	Input neutral wire disconnected	Input zero line not connected	Check for excessive unbalanced load
126	Input overload	Input overload	Check for excessive load
200	Positive bus overvoltage	Positive bus voltage over the overvoltage setting value	If the mains input or bypass input voltage is too high, after the voltage returns to normal, clear the failure, and then restart. If the voltage is still too high, replace the power unit or the module.
201	Negative bus overvoltage	negative bus voltage over the overvoltage setting value	
202	Bus overvoltage	Bus voltage over the overvoltage setting value	
203	Positive bus undervoltage	Positive bus voltage below the undervoltage setting value	Replace the power unit or the module
204	Negative bus undervoltage	Negative bus voltage below the undervoltage setting value	Replace the power unit or the module
206	Positive and negative bus voltage unbalanced	Voltage difference between positive and negative bus over the setting value	Replace the power unit or the module
207	Bus hardware overvoltage fault	Bus voltage over setting value of hardware overvoltage	Replace the power unit or the module
210	BUS overvoltage times to	Bus overvoltage over setting value	Replace the power unit or the module
211	Bus capacitance lifetime less than 1 year	Less than 1 year service life of bus capacitor	Replace the power unit or the module
212	Positive bus instantaneous undervoltage	Positive bus voltage below undervoltage setting value	Replace the power unit or the module
213	Negative bus instantaneous undervoltage	Negative voltage below undervoltage setting value	Replace the power unit or the module
218	Bus short circuit	Bus short circuit	Check bus connection, or replace the power unit or the module
219	Bus soft-start times to	Bus soft start times over set times	Replace the power unit or the module
300	Battery overtemperature	Battery temperature reaching battery overtemperature alarm point	Check whether the battery cables are loose Check whether the battery voltage or current conforms to the parameters in the battery manual Strengthen the environment ventilation of battery room Improve the grid environment

Alarm code	Alarm description	Cause	Corrective action
301	Battery self-check failure	Battery self-inspection failed	Check if the set number of battery is correct Replace the power unit or the module
302	Battery overvoltage	Battery voltage reaching battery over-voltage protection point	Check if the set number of battery is correct Replace the power unit or the module
303	Battery undervoltage (DOD)	Battery undervoltage alarm	Check whether the main circuit voltage is abnormal for a long time Check for overload
304	Battery undervoltage(EOD)	Battery voltage reaching EOD voltage value due to continuous discharging of battery	Check the mains supply and charge the battery in time
305/309	Battery overcharge	Charger failed	Replace the power unit or the module
322	Battery charge overcurrent	Charger failed	Check whether the set number of batteries is consistent with the actual number of batteries, or otherwise replace the power unit or the module
323	Battery discharge overcurrent	Battery discharge overcurrent	Check whether heavy loads are powered weak batteries and "troubleshoot" after load relief If not, replace the power unit or the module
324	Battery discharging voltage expired	Battery voltage reaching EOD voltage value due to continuous discharging of battery	Check the mains supply and charge the battery in time
325	Battery discharging time expired	Time continuous discharging of battery over discharging protection time	Check the mains supply and charge the battery in time
330	Backup time warning	Battery standby time failing to reach expected standby time	Check the mains supply and charge the battery in time Check battery configuration capacity
331	Remain capacity warning	Remaining capacity failing to expected remaining capacity	Check the mains supply and charge the battery in time Check battery configuration capacity
332	Battery maintenance reminding	Maintenance period exceeded after the previous battery maintenance	Confirm battery maintenance tips after battery maintenance
336	Battery fuse fault	Battery fuse failure	Check the battery fuse for damage
338		Battery reversal	Confirm the battery installation polarity and reinstall
339	Battery connection abnormal	Battery not connected	Check whether the battery port voltage is normal and whether the battery is installed properly Check that the battery fuse is normal
357	Battery low temperature	Too low ambient temperature of battery room	Raise the ambient temperature of the battery room
320	Charger overvoltage	Charger overvoltage	Check whether the number of batteries is set correctly, and "troubleshoot" after confirmation.
321	Charger undeervoltage	Charger undervoltage	If the failure is not removed, replace the power unit or the module
322	Charger overcurrent	Charger overcurrent	Replace the power unit or the module
335	Charer soft-start failure	Charger soft start failed	Replace the power unit or the module
346	Charger brearker short circuit	Charger switch shorted	Replace the power unit or the module

Alarm code	Alarm description	Cause	Corrective action
347	Charger breaker open circuit	Charger switch opened	Check whether the difference between the charging voltage and the battery voltage is within the error range. If it is beyond the error range, re-calibrate charging voltage and battery voltage Replace the power unit or the module
348	Charger overtemperature	Charger overtemperature	Check the fan and turn off the charger
349-350	Charger hardware overvoltage fault	Charger hardware overvoltage fault	Check whether the number of batteries is set correctly, and "troubleshoot" after confirmation. If the failure is not removed, replace the power unit or the module
351-352	Charger hardware wave-by-wave current-limiting alarm	Wave-by-wave current limit alarm of charger hardware	
353-354	Charger hardware wave-by-wave current-limiting fault	Wave-by-wave current limit failure of charger hardware	Replace the power unit or the module
400	Input AC software failure	Soft start failed of input AC	Replace the power unit or the module
401	Battery DC soft-start failure	Soft start failed of battery DC	Replace the power unit or the module
402	Bus DC/DC soft-start failure	Soft start failed of BUS DC/DC	Replace the power unit or the module
403	Input phase-lock failure	Input phase lock failed	Replace the power unit or the module
404	Mains power supply and battery switching frequently	Frequent switching between mains and batteries	Check grid quality, and otherwise replace the power unit or the module
405	PFC soft-start times to	Soft start times of rectifier over setting value	Replace the power unit or the module
406-411	Rectifier hardware wave-by-wave current-limiting alarm	Wave-by-wave current limit alarm of rectifier hardware	Check for excessive load or transient load
412-417	Rectifier hardware overvoltage fault	Overcurrent failure of rectifier hardware	Check for excessive load, otherwise replace the power unit or the module
418-423	Rectifier overcurrent	Rectifier overcurrent	Replace the power unit or the module
424-429	Rectifier hardware wave-by-wave current-limiting fault	Wave-by-wave current limit alarm of charger hardware	Check for excessive load, otherwise replace the power unit or the module
430	Bus hardware soft-start failure	Soft start failed of bus hardware	Replace the power unit or the module
447	Rectifier overcurrent in battery mode	Overcurrent of rectifier battery mode	Replace the power unit or the module
448	Rectifier overcurrent in mains mode	Overcurrent of rectifier mains mode	Replace the power unit or the module
500-505	PFC IGBT module overtemperature	Rectifier IGBT module over-temperature	Check whether the fan is normal or the ambient temperature is too high or it runs at one above the full load power for long time

Alarm code	Alarm description	Cause	Corrective action
506	E2PROM read-write failure	E2PROM read/write failure	Replace the power unit or the module
507	PFC DSP and monitoring communication failure	Communication between rectifier DCP and monitor failed	Check whether the communication cables are connected properly Replace the power unit or module or monitoring unit
508	PFC DSP and CPLD communication failure	Communication between rectifier CPLD and monitor failed	Replace the power unit or the module
509-511	Fan fault	Fan failed	Check whether the fan is blocked. If so, restore the fan to normal operation. Otherwise, replace the power unit
512	Rectifier APS abnormal	Abnormal auxiliary power supply of rectifier	Replace the power unit or the module
515	PFC contactor fault	Rectifier contactor failed	Replace the power unit or the module
516	CPLD software version abnormal	Abnormal CPLD software version	Load the software
517	DSP software version abnormal	Abnormal DSP software version	
518	PFC software version asnd hardware mismatching	Rectifier software version unmatched with the hardware version	
520	PFC emergency stop	Emergency shutdown of rectifier	Check the status of the emergency shutdown button, troubleshooting
525	SPI communication fault among rectifier and inverter	SPI communication failure between rectifier and inverter	Replace the power unit or the module
600-602	Bypass overvoltage	Bypass overvoltage	Check the bypass input voltage or wiring Check whether the voltage system and upper and lower limits of bypass voltage are reasonable
603-605	Bypass undervoltage	Bypass undervoltage	Check the bypass input voltage or wiring Check whether the voltage system and upper and lower limits of bypass voltage are reasonable
607	Bypass over-frequency	Bypass over-frequency	Check the bypass input frequency Check whether the rated frequency and frequency range settings are reasonable
608	Bypass under-frequency	Bypass under-frequency	Check the bypass input frequency Check whether the rated frequency and frequency range settings are reasonable
617	Bypass phase sequence reversed	Bypass phase sequence reversed	Check three-phase bypass input wiring
619-621	Bypass open circuit fault	Bypass SCR opened	Replace the power unit or the module
622-624	Bypass SCR short circuit fault	Bypass SCR shorted	
625-626	Bypass APS fault	Auxiliary power failure of bypass	Manually remove Replace the bypass unit
627	Bypass overload (125%)	Bypass overload 125% time out	Check whether the load is too large Check whether the module is derated due to fan failure
629	Bypass overload (150%)	Bypass overload 150% time out	If no, replace the power unit or the

Alarm code	Alarm description	Cause	Corrective action
647	Bypass overload (200%)	Bypass overload 200% time out	module
655	Bypass overload alarm	Bypass with bypass overload alarm	automatically clear after load reduction
631	Bypass DSP and monitoring communication failure	Communication between bypass DSP and monitor failed	Replace bypass unit or monitoring module
633	Bypass DSP software version abnormal	Abnormal bypass DSP software version	Load the software
635	Bypass software version and hardware version mismatching	Bypass software version unmatched with hardware version	
636	Bypass E2PROM operation failure	Bypass E2PROM operation failed	Replace bypass unit or module
644-646	Bypass overtemperature	Bypass overtemperature	Check whether the bypass output is overcurrent. If yes, lower the load Check whether the fan duct is blocked. If yes, remove the obstruction Check whether the fan is blocked. If yes, restore the fan to normal operation. Otherwise, replace the power unit
656-658	ECO bypass overvoltage	ECO bypass overvoltage	Check the bypass input voltage or wiring Check whether the voltage system and upper and lower limits of bypass voltage are reasonable
659-661	ECO bypass undervoltage	ECO bypass undervoltage	Check the bypass input voltage or wiring Check whether the voltage system and upper and lower limits of bypass voltage are reasonable
662	ECO bypass over-frequency	ECO bypass overfrequency	Check the bypass input frequency Check whether the rated frequency and frequency range setting are reasonable
663	ECO bypass under-frequency	ECO bypass underfrequency	Check the bypass input frequency Check whether the rated frequency and frequency range setting are reasonable
707	Output overload 105%	Output overload 105% time out	Check whether the load is too large Check whether the module is derated due to fan failure If no, replace the power unit or the module
708	Output overload 110%	Output overload 105% time out	
709	Output overload 125%	Output overload 125% time out	
710	Output overload 150%	Output overload 150% time out	
721	Output overload alarm	Output overload alarm	automatically clear after load reduction
800-802	Inverter overvoltage	Inverter overvoltage	Replace the power unit or the module
803-804	Inverter undervoltage	Inverter undervoltage	Replace the power unit or the module
806	Inverter voltage unbalanced	Inverter voltage unbalance	Replace the power unit or the module
807-809	DC components too large (RST)	Oversize DC component (R S T)	First check whether the load is a special load (such as half-wave load). If the load is normal, replace the power unit or the module

Alarm code	Alarm description	Cause	Corrective action
901	Inverter phase-lock failure	Phase lock failure of inverter	Replace the bypass unit or module
902	Bypass and inverter switching frequently	Switching frequently between bypass and inverter	Check the quality of the bypass power system, and clear the faults automatically Otherwise, replace the power unit or the module
903	Inverter soft-start times to	Inverter soft start times reached	Replace the power unit or the module
904	Parallel equalized current abnormal	Abnormal even current of parallel operation	Replace the power unit or the module
905	Inverter self-check failure	Inverter self-inspection failed	Replace the power unit or the module
1000-1005	Inverter radiator overtemperature	Temperature of inverter heat sink over setting value	Check whether the bypass output is overcurrent. If yes, lower the load Check whether the fan duct is blocked. If yes, remove the obstruction Check whether the fan is blocked. If yes, restore the fan to normal operation. Otherwise, replace the power unit
1006-1013	Inverter hardware overcurrent fault	Overcurrent failure of inverter hardware	Check whether the load is too large, and the large nonlinear load is applied transiently, if the load is normal, replace the power unit or the module
1022-1024	Inverter output short circuit	Inverter output shorted	Check whether the output end is shorted, if yes, replace the power unit; If no, check the load cable.
1026	Inverter power supply abnormal	Abnormal inverter power supply	Manually clear Replace the power unit or the module
1027	Inverter contactor fault	Inverter contactor failed	Replace the power unit or the module
1028	Inverter CPLD software version abnormal	Communication between inverter DSP and monitor	Check if the CCB communication line is connected properly, otherwise replace the power unit or monitoring unit
1029	Inverter DSP software version abnormal	Communication between inverter DSP and system board	Check if the CCB communication line is connected properly, otherwise replace the power unit or monitoring unit
1030	Inverter CPLD software version abnormal	Abnormal inverter CPLD software version	Load the software
1031	Inverter DSP software version abnormal	Abnormal inverter DSP software version	
1032	Inverter software version and hardware version mismatching	Inverter software version unmatched with hardware version	
1033	Inverter E2PROM operation failure	Inverter E2PROM operation failed	Replace the power unit or the module
1034	Inverter DSP and monitoring communication failure	Communication between Inverter DSP and CPLD failed	Replace the power unit or the module
1036-1038	Inverter fuse fault	Inverter fuse failed	Check the inverter fuse for damage

Alarm code	Alarm description	Cause	Corrective action
1039	Emergency stop	Emergency shutdown of inverter	Check the status of the emergency shutdown button, troubleshooting
1014-1019	Inverter hardware wave-by-wave current-limiting alarm	Wave-by-wave current limit alarm of inverter	Check whether the load is too large, and the large nonlinear load is applied transiently, if the load is normal, replace the power unit or the module
1048-1053	Inverter hardware wave-by-wave current-limiting fault	Wave-by-wave current limit failure of inverter	Check whether the load is too large, and the large nonlinear load is applied transiently, if the load is normal, replace the power unit or the module
1056	Inverter module overload (105%)	Inverter module overload 105% time out	Check whether the load is too large Check whether the module is derated due to fan failure If no, replace the power unit or the module
1057	Inverter module overload (110%)	Inverter module overload 110% time out	
1058	Inverter module overload (125%)	Inverter module overload 125% time out	
1059	Inverter module overload (150%)	Inverter module overload 150% time out	
1072	Inverter module overvoltage alarm	Inverter load over full-load power alarm	automatically clear after load reduction
1068	Synchronized method abnormal	Abnormal synchronous square wave	Check whether the connection of synchronous square wave signal line is normal Replace the power unit or the module
1069	Inverter contactor open circuit fault	Inverter relay open-circuit fault	Replace the power unit or the module
1070	Inverter contactor short circuit fault	Inverter relay short-circuit fault	
1080	Load impact	Load impact	Check whether the large nonlinear load is applied transiently Check output load for short circuit If the load is normal, replace the power unit or the module
1100	System board and inverter module CAN communication abnormal	Abnormal communication between system board and inverter module CAN	Check whether the communication line connection between the system and the inverter module is normal
1101	Multiple inverter addresses identical	Same address of multiple inverters	Check whether the address settings of each inverter module are conflict
1109	System self-check failure	System self-inspection failed	Replace the power unit or the module
1111	Load impact to bypass	Load impact switching to bypass	Check whether the large nonlinear load is applied transiently Check output load for short circuit If the load is normal, replace the power unit or the module
1200	CAN communication abnormal among system boards	Abnormal communication between system board and CAN	Check whether the communication line connection between system boards is normal
1201	System overload (105%)	System overload 105% time out	Check whether the load is too large Check whether the module is derated due

Alarm code	Alarm description	Cause	Corrective action
1202	System overload (110%)	System overload 110% time out	to fan failure If no, replace the power unit or the module
1203	System overload (125%)	System overload 125% time out	
1204	System overload (150%)	System overload 125% time out	
1205	System overload alarm	System load over designed full load of system	automatically clear after load reduction
1317	Neighbor requests to bypass	Adjacent machine requesting change to bypass	Check the adjacent machine for request cause
1329	Repeatedly transfer to bypass	Bypass locked due to repeated switching	Check whether the transient load is applied frequently, lock delay time to auto clearance
1330	Repeatedly transfer to inverter	Inverter locked due to repeated switching	Check whether the transient load is applied frequently, lock delay time to auto clearance

Appendix 3 Abbreviations

A	
AC	Alternating Current
AWG	American Wire Gauge
C	
CAN	Controller Area Network
CE	Conformite Europeenne
D	
D.G.	Diesel Generator
DC	Direct Current
DSP	Digital Signal Processing
E	
ECM	Energy Control Module
ECO	Economy Control Operation
EMC	Electro Magnetic Compatibility
EOD	End Of Discharge
EPO	Emergency Power Off
H	
HMI	Human Machine Interface
I	
IDC	Internet Data Center
IEC	International Electrotechnical Commission
IP	Internet Protocol
L	
LBS	Load Bus Sync
LCD	Liquid Crystal Display
LED	Light Emitting Diode
P	
PCB	Printed Circuit Board
PDC	Power Distribution Cabinet
PE	Protective Earthing
R	
RS232	Recommend Standard 232
RS485	Recommend Standard 485
S	
SNMP	Simple Network Management Protocol
STS	Static Transfer Switch
SN	Serial Number
T	
THDi	Total Harmonic Distortion Rate Of Current
THDv	Total Harmonic Distortion Rate Of Voltage
U	
UI	User Interface
UPS	Uninterruptible Power System
V	
VRLA	Valve Regulated Lead Acid