

Table Of Contents

- 1 Product Description 1**
- 2 Safety Information 1**
- 3 Product Overview 4**
 - 3.1 Specifications 4
 - 3.2 Panel Features 6
 - 3.3 System Principle 7
- 4 Installation 8**
 - 4.1 Packing list 8
 - 4.2 Installation 8
- 5 Electrical Connection 11**
 - 5.1 System Connection 12
 - 5.2 Connect Utility Grid 14
 - 5.3 Connect PV 16
 - 5.4 Connect the Battery 17
 - 5.5 Connect the load 18
 - 5.6 Communications 19
- 6 Operation 20**
 - 6.1 Control Panel 20
 - 6.2 Button Description 20
 - 6.3 LED Indicator 21
 - 6.4 LCD Menu structures 21
 - 6.5 System Information Inquiry 23
 - 6.6 Factory Information Inquiry 24
 - 6.7 Switching On and Off 24
 - 6.8 Self-test 24
- 7 Settings 26**
 - 7.1 User Settings 26
 - 7.2 Advanced Settings 27
 - 7.3 Language 28
 - 7.4 TIME Settings 28
 - 7.5 Communication Settings 29
 - 7.6 Password Settings 29

- 7.7 Contrast Settings 30
- 7.8 Factory Reset 30
- 7.9 Timer Switch (3KW only) 30
- 8 Work Mode 31**
- 8.1 3KW Work Mode..... 31
- 8.2 3.6KW Work Mode..... 33
- 9 Maintenance..... 34**
- 9.1 Preventive Maintenance 34
- 9.2 Battery maintenance 34
- 10 Troubleshooting 35**
- 10.1 History Records 35
- 10.2 Clear History Records 35
- 10.3 Fault List 36
- 11 Appendix 40**
- 11.1 Terminology paraphrase 40
- 11.2 Running mode (Products series) 41

1 Product Description

Hybrid (Bi-direction) Solar Inverter is PV energy combined with energy storage systems. It utilizes solar power, utility power and battery power to ensure continuous power supply, and users can store the unused energy produced during the day by PV system in the battery and use it whenever they needs. Even at night, It can also charge the battery through the grid (3KW only) or use only the battery to ensure energy supply.

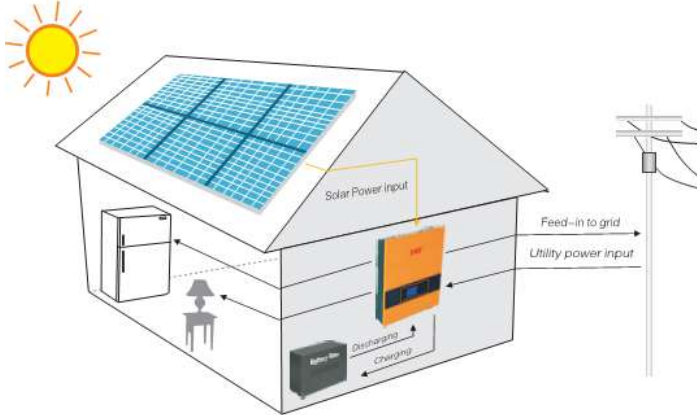



2 Safety Information









- All terminals of the inverter must be equipped with protective cover.
- If this is your first time to use the inverter, please make sure that all the parameters are set correctly, especially the parameters of the battery and the working mode (ANTI-TIED or GRID-TIED).
- When the inverter works, the battery terminal may be charged. If there is no connection to the battery, please cover with the protection of pearl cotton in the protective cover.
- It is forbidden to short-circuit the positive and negative poles of the battery. The electrodes of each battery in the battery pack need to be protected with an insulating shield.
- It is normal that the case surface temperature goes up to 50°C during using.
- When the photovoltaic module and the battery have sufficient energy, the inverter will automatically start. But not use inverter with overload.
- Do not open the inverter cover in case of danger of electric shock. Maintenance should be done by technicians.
- Inverter inner short circuit will cause electric shock or fire danger. Do not put any liquid vessel on inverter.
- Cut off power rapidly if inverter works abnormally, and contact your local dealer.
- Make sure not to keep or use the product in following environment.

- No good air circulation
 - Place having flammable gas or corrosive material or lots of dust
 - Place under abnormal high or low temperature (above 40°C or below 0°C), or high humidity (above 90%)
 - Place where there is direct sunlight or near the heating appliance
 - Place where there is violent vibration
 - Outdoor
- Do not use liquid extinguisher if there is a fire, a dry powder extinguisher is recommended.
 - Please install a small breaker in the input and output terminals of the inverter (The minimum rated voltage and current of PV side DC circuit breaker is 500V.dc/18A.dc, the minimum rated voltage and current of AC circuit breaker on the grid side is 230V.ac/32A.ac, and the minimum rated voltage and current of the DC circuit breaker on the battery side is 60V.dc/100A.dc), so that in emergency situation the switch can be disconnected and power supply can be cut off.

Important Safety Information

- Only qualified electricians are allowed to install and maintain the inverter.
- Read these instructions carefully and look at the equipment to become familiar with it before trying to install, operate or maintain it.
- The connection to the Grid must be done only after receiving approval from the distribution utility as required by national and state interconnection regulations, and can be done only by qualified personnel.
- Comply with all corresponding marks and symbols appearing on the equipment. During operation, ensure that all terminals and protective covers and doors are installed.
- Ensure that the inverter is reliably grounded before running.

	<p style="background-color: red; color: white; padding: 2px;">DANGER!</p> <p>Unauthorized removal of the necessary protections, improper use, wrong installation or wrong operation will result in serious injury or equipment damage Transport, handling, installation, start-up and maintenance must be performed by qualified and trained personnel.</p>
	<p style="background-color: red; color: white; padding: 2px;">DANGER!</p> <p>After disconnecting the inverter from the Grid, wait for 60 seconds until the internal capacitors are discharged to a safe voltage before servicing or touching any electrified parts and electric connection.</p>

	<p>DANGER!</p> <p>It's forbidden to connect the load N line to the Grid N line. It may cause serious damage to the machine and the load.</p>
	<p>DANGER!</p> <p>The internal heatsink of the inverter is ungrounded, it may be electriferous during operation.</p>
	<p>WARNING!</p> <p>The installation must be performed in full compliance with national and local standards and regulations.</p>
	<p>WARNING!</p> <p>You can only use monocrystalline silicon and polycrystalline silicon modules due to non-isolated topologies of PV and Grid side of the inverter.</p>
	<p>WARNING!</p> <p>When the photovoltaic array is exposed to light, it supplies a DC voltage to the PCE. To ensure a safe work environment, keep the whole surface of the photovoltaic panel covered with opaque material to solar radiation before connecting panel to equipment.</p>
	<p>WARNING!</p> <p>Ensure that the PV generators open voltage does not exceed 500V, otherwise it will cause damage to the inverter permanently and cause other losses (Please consider the influence of the temperature factor, usually the PV module voltage will be about 15% higher in winter (-20 °C) than that in summer (30 °C). Do not connect any source of energy other than PV modules to the inverter PV input.</p>
	<p>WARNING!</p> <p>Do not change the internal components of the inverter without permission.</p>
	<p>WARNING!</p> <p>The equipment must be connected to the ground before connecting to the Grid, ensure that the ground connection is reliable. Loss of abnormal operating is enormous; Do the operation according to the specifications of the operation manual.</p>

	<p>Notice</p> <p>The inverter is equipped with RS485, USB, SNMP card, but only one at the same time.</p>
---	---

3 Product Overview

3.1 Specifications

Model	3KW	3.6KW
Rated power	3000 W	3600 W
Operating mode	Flexible setup via upper computer software or LCD interface	
PV input		
Max. input power	4500 W	
Rated input voltage	360 Vdc	
Max. input voltage	500 Vdc	
Start-up voltage	115 Vdc	
Initial feeding voltage	150 Vdc	
MPPT voltage range	250 Vdc ~ 450 Vdc	
Max. input current	18 A	
PV short circuit current	18 A	
Number of MPPT	1	
Batteries		
Battery type	Lithium battery	
Rated voltage	51.2 Vd.c	
Voltage range	46.4 Vd.c ~ 57.6 Vd.c	
Battery type	Lead-acid battery	
Rated voltage	48 Vd.c	
Voltage range	40 Vd.c ~ 58Vd.c	
Battery capacity	100 Ah – 120 Ah optimized	
Rated charging power	1500W	
Max. charge current	25 A (5 A / 10 A / 15 A / 20 A / 25 A settable)	
Charging curve	3-Stage	
Max. charge efficiency	94%	
Rated discharge power	3000 W	
Max. discharge current	100 A	
Discharge depth (%)	80% default (50%Lead-acid / 90%Lithium ,optimized)	

Max. discharge efficiency	94%	
AC grid input		
AC start-up voltage	120 Vac	
Grid voltage range	170 ~ 280 Vac	
Rated grid frequency	50 Hz / 60 Hz	
Allowed grid frequency	50 ± 5 Hz / 60 ± 5 Hz	
Rated output power	3000VA/3000W	3600VA/3600W
Power factor range	0.9 leading ~ 0.9 lagging	
Load output		
Rated output power	3000 VA / 3000 W	
Over load	4000VA/1min	
Rated output voltage	230 Vac (208 / 220 / 240 settable)	
Rated output current	13.0 A (14.4 A / 13.6 A / 12.5 A)	
Output voltage range	184 Vac ~ 264.5 Vac	
Rated output frequency	50 Hz / 60 Hz	
Output frequency precision	± 1%	
Power factor	0.9 leading ~ 0.9 lagging	
Output voltage precision	± 1%	
Transient recovery time	≤ 40 ms	
Peak factor	3:1	
Linear load waveform distortion	≤ 3%	
Short circuit current	45 A (100 ms)	
Transfer time		
Off-grid mode → On-grid mode	0 ms	
On-grid mode → Off-grid mode	10 ms	
Efficiency		
MPPT efficiency	99%	

Max. PV efficiency	96%
Others	
Dimensions (W×H×D) (mm)	410 ×470 ×123
Weight (kg)	14.4
Communications	USB / RS485 / WIFI,GPRS,SNMP (optional)
IP rating	IP 20
Operating temperature	0 ~ 40℃ (> 40℃ derating)
Max. relative humidity	0 ~ 90%
Max. altitude	<1000 m (>1000 m derating)
Cooling	Forced ventilation
Alarm	LED, buzzer
Display	LED, LCD
Noise	≤ 50 dB
Topology	Transformerless

Note:

The anti reflux function of digital meter/CT model needs digital ammeter or external CT, and it is suitable for lithium battery and lead-acid battery that supports deep circulation charge and discharge. Standard model does not have this limitation.

3.2 Panel Features

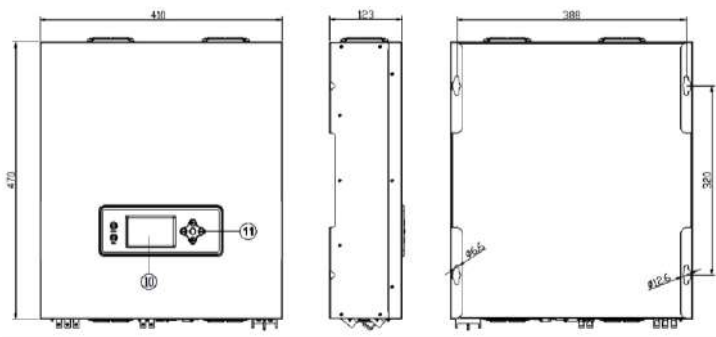

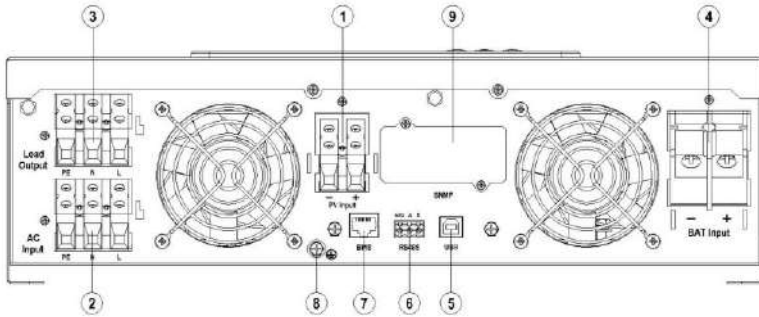

No.	Mark	Usage
1	PV Input	PV connectors
2	AC Input	Grid connectors
3	Load Output	Load connectors
4	BAT Input	Battery connectors
5	USB	USB communication port
6	RS485	RS485 communication port
7	BMS	BMS communication port
8	PE	Grounding
9	SNMP	SNMP card/WIFI/GPRS
10	LCD	LCD display panel
11	Buttons	Operation buttons

3.3 System Principle

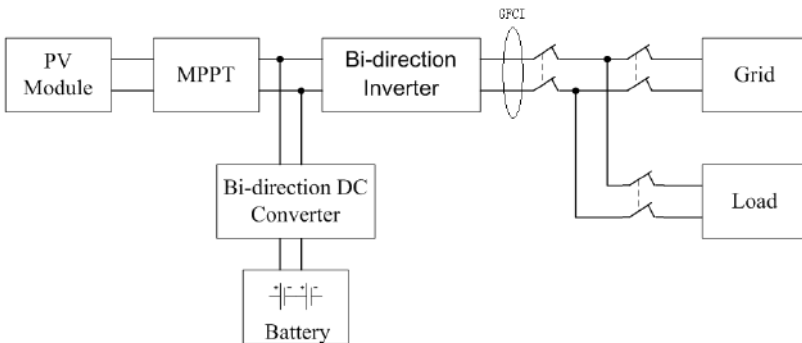

4 Installation Instructions

4.1 Packing list

Standard configurations:

No.	Machine or accessories	Quantity
1	Inverter	1
2	Manual	1
3	Battery connection head	2
4	PE connection head	1
5	Wiring sheath	8
6	USB line	1
7	Fixed screw	4
8	Expansive tube	4

Optional:

No.	Accessories	Quantity	Note
1	Crystal joint	1	ANTI-TIED Mode by external digital meter
2	22cm network wire	1	
3	3M network wire	1	
4	3Pin terminal	1	
5	Digital meter	1	

Optional:

No.	accessories	Quantity	Note
1	CT	1	ANTI-TIED Mode by external CT
2	3Pin terminal	1	

The 3.6KW inverter is equipped with AC meter and CT, but only one at the same time. Inspect the contents upon receipt. Notify the carrier and dealer if the unit is damaged.

4.2 Installation

4.2.1 Mounting

Selecting the mounting location

- The ambient temperature should be between 0°C ~ +40°C and relative humidity should be between 0% ~ 90% (non-condensing) to ensure optimal operation.
- Mount indoor only. The protection level of this product is IP 20.
- The inverter can make noises (< 50dB) when in use, mount the inverter away from people's living area.
- Select a location that allows unobstructed airflow around the inverter. There must be sufficient clearance between the individual inverters and make sure there is enough fresh-air supply to ensure optimum operation of the inverters.

- Allow sufficient space around the inverter to enable easy installation and removal from the mounting surface.
- The mounting location and method must be suitable for the weight and dimensions of the inverters.
- Mount vertically or tilted backwards by max. 15°. Never mount it with a forward tilt. Do not mount in a horizontal position.
- Mount the inverter in such a way that the display is at eye level in order to allow the operating state to be read at all times.
- Regularly clean the fan filter.
- The pollution degree of the inverter is PD2. Select an appropriate mounting location where is dry, free of excessive dust and has adequate air flow.
- The wiring terminal should be installed protective covers.

Pollution degree definition

Pollution degree 1: No pollution or only dry, no-conductive pollution occurs.

Pollution degree 2: Normally only non-conductive pollution occurs. Occasionally, however, a temporary conductivity caused by condensation must be expected.

Pollution degree 3: Conductive pollution occurs, or dry, non-conductive pollution occurs which becomes conductive due to condensation which is expected.

Pollution degree 4: Persistent conductive pollution occurs, for example, the pollution caused by conductive dust, rain and snow.

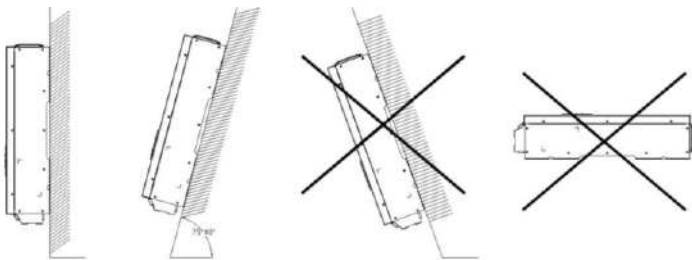

In order to maintain sufficient ventilation, when installing the inverter, a minimum clearance that is not less than below distances at the sides and top must be maintained.

- The top.....300mm
- The bottom.....300mm
- The front.....300mm
- Both sides.....300mm

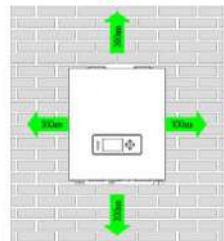

4.2.2 Installation Steps

1. Drill four holes at the marked locations with four screws according to dimensional layout. It is recommended to use M4 screws and matched bulged tube, and the diameter of screw cap should be 8 ~ 10 mm. Ensure the inverter LCD screen height is flush with the eyes of the user for easy operation.
2. There are 4 gourd-shaped mounting holes on the rear panel of the inverter, align the mounting holes with the fixed 4 screws, then attach the inverter to the wall. Remember that this inverter is 14kg. Be careful when mounting.
3. Check if the inverter is firmly mounted.

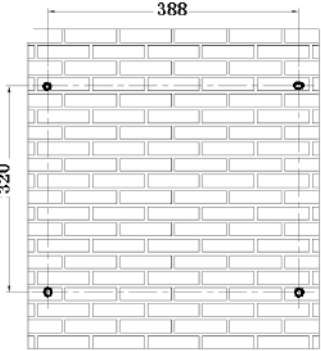
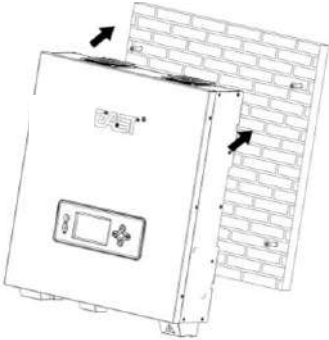
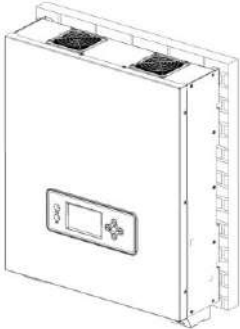
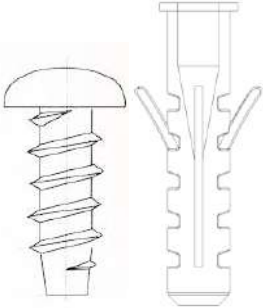
<p>Step 1</p> 	<p>Step 2</p> 
<p>Step 3</p> 	<p>Note: use screws and expansion tube in the accessories.</p> 

5 Electrical Connection

When selecting external wiring cables, cable current capacity and system overload capacity should be considered, as well as environment temperature and physics support. The following table is a proposal for cable selection. Engineers should refer to the relevant local standards and the table below to make a comprehensive selection. The length of the cables is generally 2 to 10 meters; long cable will cause the voltage decrease, the corresponding cable cross-sectional area sizes should be increased.

Item	Conductor cross-sectional area	Breaker Type
AC Input (L,N,PE)	4~6 mm ²	250VAC/40A
Load Output (L,N,PE)	4~6 mm ²	250VAC/40A
PV Input (+,-)	4~6 mm ²	600VDC/25A
BAT Input (+,-)	20~25 mm ²	60VDC/100A

The Grid input, AC output, PV input cables should be installed with insulated cord end terminals. Use crimping tool to make the terminal fixed firmly. These terminals should be clamped properly, which will make the system wiring more secure and reliable.

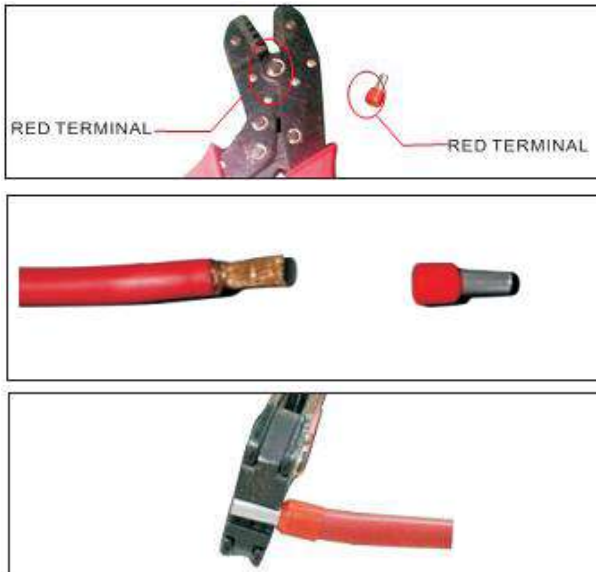

5.1 System Connection



NOTICE

The load carrying capacity of the load output terminal indicates that (take 3KW for example):

Inductive load (such as air conditioner, washer, motor etc): Single inductive load power ≤ 1.5 KVA, total Inductive load power ≤ 2.5 KVA (without Grid)

Single Inductive load power ≤ 5.1 KVA, total Inductive load power ≤ 5.1 KVA (with Grid)

Capacitive load (such as computer, switch power etc):

Total capacitive load power ≤ 2.5 KVA (without Grid)

Total capacitive load power ≤ 5.1 KVA (with Grid)

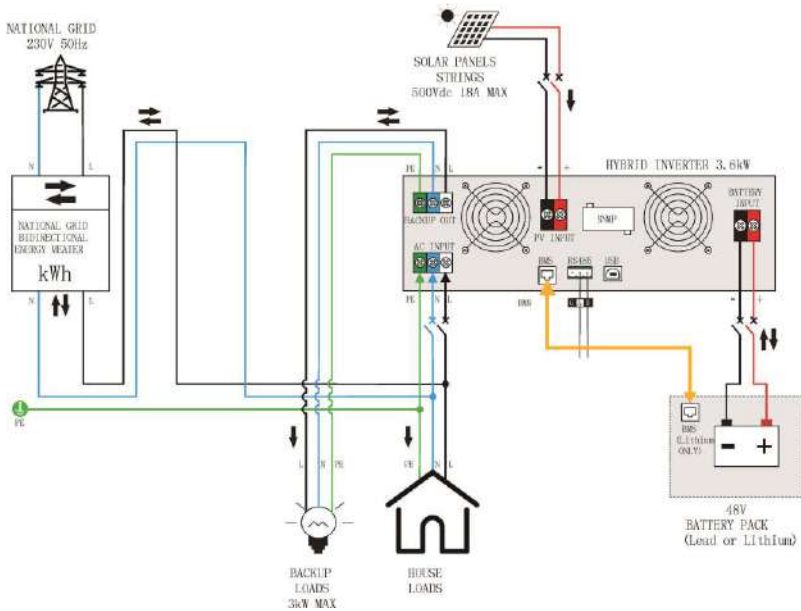

Connection diagram (3KW)

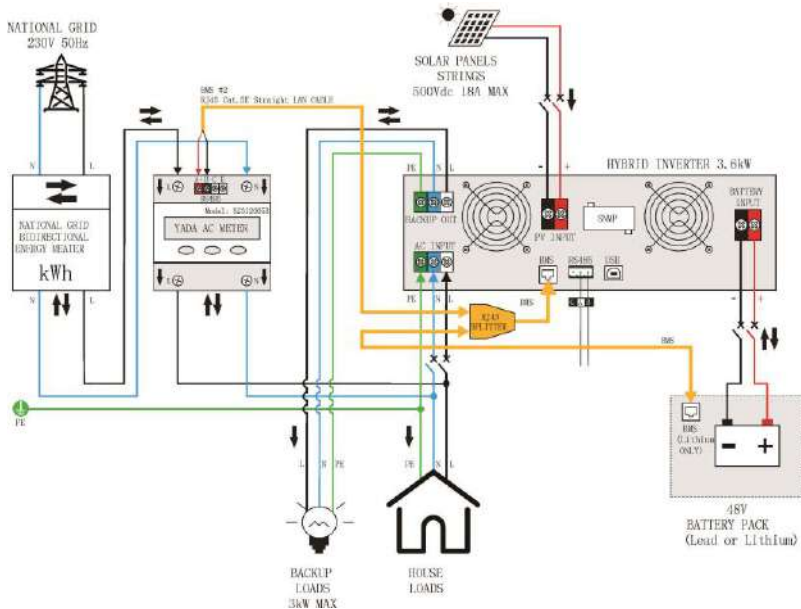

3.6KW Wiring diagram (Digital meter type)

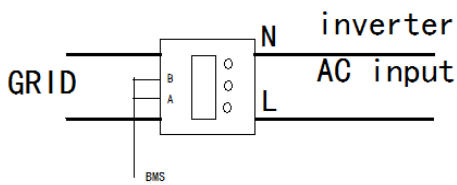

Meter connection

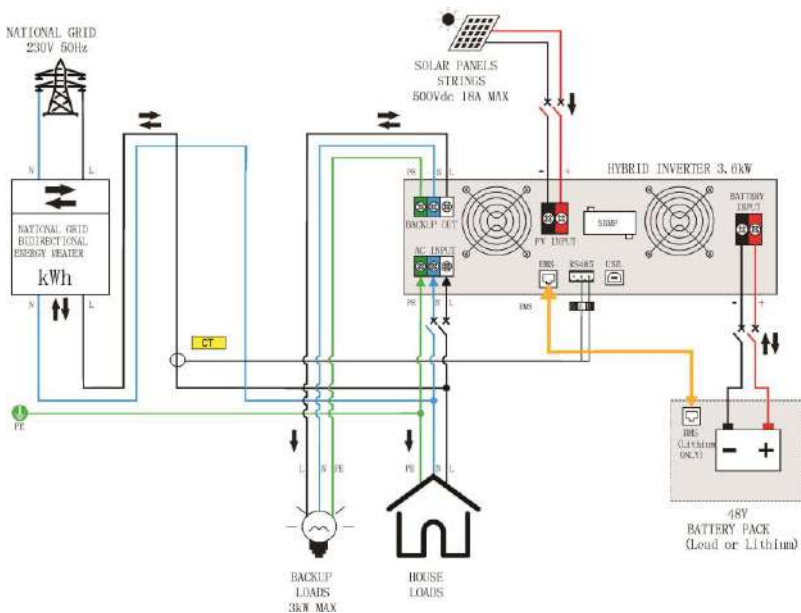

3.6KW Wiring diagram (CT type)

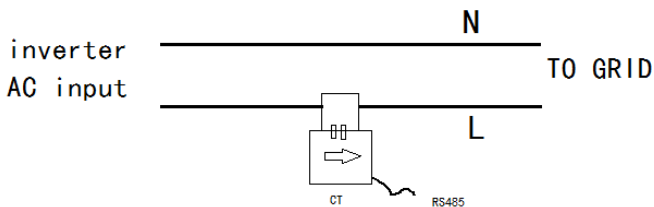

CT connection

5.2 Connect Utility Grid

Requirements

- Install an AC circuit breaker between inverter and power grid before connecting to Grid.
- The Grid voltage and frequency must be within the permissible range.

Procedures

- Disconnect the circuit breaker and ensure that it is not closed.
- Strip the insulation layer of L, N and PE by 10 mm. Shorten L and N by 5 mm than PE.

- Connect PE protective conductor first, then connect N and L to the connecting terminal plate for the Grid cable in accordance with the labelling. The recommended colours of the cables connecting each polarity are shown in the following fig

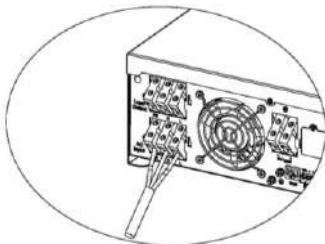

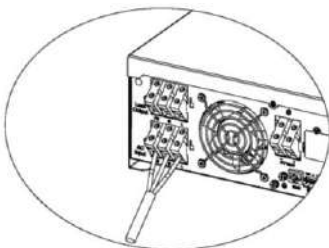

PE→ Ground (yellow-green)
N→ Neutral (black/blue)
L→ LIVE (red/brown)

- Ensure that all conductors and wires are firmly connected. The reference tightening torque is 1.5 N.m.
- After connecting the AC cable, place the protective cover and fix it with screws.

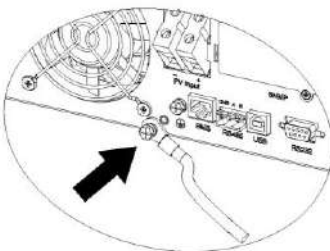

- Use one more wire (4–6 mm²) with ring terminal to connect Additional Grounding.



	Notice
	<p>Ensure the ground wire is properly earthed before operating this hybrid inverter whether the Grid is connected or not, do NOT connect the backup loads to “AC Input Connector”, otherwise the inverter can not provide power supply for load after the power is cut off.</p>

5.3 Connect PV



WARNING!

You can only use monocrystalline silicon and polycrystalline silicon modules due to non-isolated topologies of PV and Grid side of the inverter.

Requirements

- All PV modules must be of the same type and have the same tilt angle.
- The thresholds for the input voltage and the input current of the inverter must be adhered to the requirements of the inverter specification.
- Before connecting to PV modules, install separately a DC circuit breaker between inverter and PV modules.

Procedures

- Disconnect all circuit breakers.
- Check connection cable of one PV array string for correct polarity. Ensure that the maximum input open circuit voltage does not exceed 500V and the maximum allowable short-circuit current of the connected modules does not exceed 18A.
- Remove insulation sleeve 10 mm for positive and negative conductors.
- Check correct polarity of connection cable from PV modules and connect PV+ cable to positive pole (+) of PV input connector. Connect PV- cable to negative pole (-) of PV input connector.

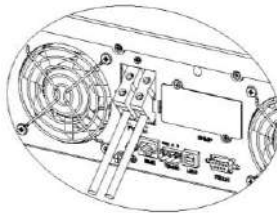

- Ensure that all conductors and wires are firmly connected. The reference tightening torque is 1.5 N.m.
- After connecting the PV cable, place the protective cover and fix it with screws.

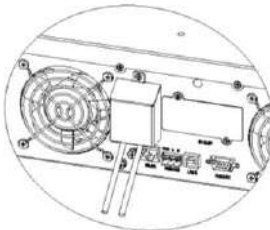

5.4 Connect the Battery

Requirements

- Install a separate DC circuit breaker between inverter and batteries before connecting to batteries.
- Check maximum charging voltage and current when first using this inverter.

Procedures

- Check that if the battery polarity and voltage are normal, and detect that if the battery voltage is within the allowable range of the inverter specification.
- There are battery cable connection terminals attached with the packing. Strip the insulation layer of the battery cable by 5 mm, put the cable in the terminal line hole through the mounting hole of protective cover, and press it firmly with a crimping plier. Insulate the terminal tail with insulation tape or thermoplastic tube. Pay attention to do the insulation treatment, otherwise it may cause battery short-circuit during installation.

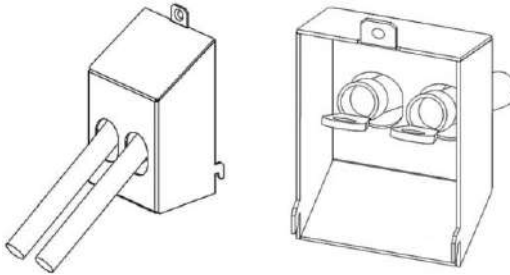

- Through the OT terminal of the battery cable, connect the positive side of the battery connection cable to the positive side of the battery; the negative side of the battery connection cable to the negative side of the battery.

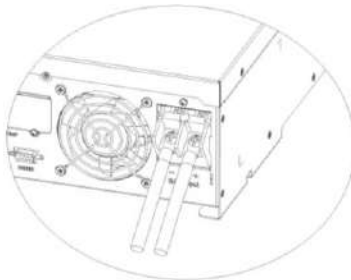

- Ensure that all conductors and wires are firmly connected. The reference tightening torque is 2.5 N.m.

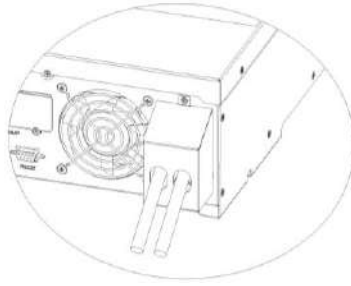

- After connecting the battery cable, place the protective cover and fix it with screws.

5.5 Connect the load

Procedures

- Disconnect the circuit breaker between the inverter and load.
- Strip the insulation layer of L, N and PE by 8 mm. Make N shorter 5 mm than PE and L.
- Connect PE protective conductor first, then connect N and L to the load terminal block in accordance with the labelling.

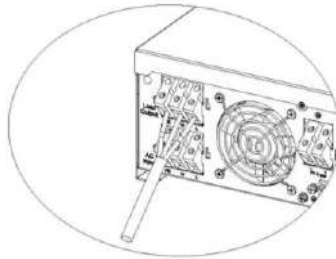

PE→Ground (yellow-green) N→Neutral (black/blue) L→LIVE (red/brown)

- Ensure that all conductors and wires are firmly connected. The reference tightening torque is 1.5 N.m.
- After connecting the load cable, place the protective cover and fix it with screws.

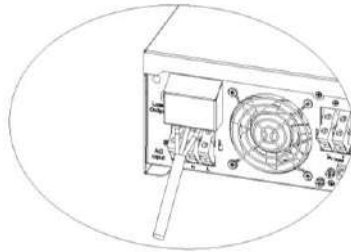

WARNING!



As long as the inverter is working, the load output has electricity, do not touch the load output and its connection cables.

5.6 Communications

The inverter is equipped with RS485, BMS and USB ports and it is also equipped with a slot for SNMP card communication interfaces (optional) in order to communicate with a PC with corresponding software.

Note:

1. If use BMS and electricity meter at the same time, please set BMS to add 1 (EAST) or BMS to add 2 (Pylontech).
2. If the BMS cannot communicate, please change the BMS address (1-8) .At the same time, check whether it is consistent with the address of the battery module (generally, the lithium battery module has a dial switch to set the communication address).

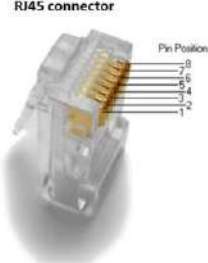
	
<p>For USB port, you should use a USB cable</p>	<p>For RS485 port, you should use a RS485 cable</p>
	 <p>RJ45 connector</p> <p>Pin Position</p> <ul style="list-style-type: none"> Pin1 : Reserved Pin2 : Reserved Pin3 : Reserved Pin4 : RS485 B- (T/R-) Pin5 : RS485 A+ (T/R+) Pin6 : Reserved Pin7 : GND Pin8 : GND
<p>For BMS port, you should use a BMS cable</p>	<p>For BMS connector (BMS needs to match agreement. For specific agreements, please apply to the agent).</p>

Install monitoring software in your computer. Detailed information is listed in the next chapter. After software is installed, you may initialize the monitoring software and extract data through communication port.

	<p>WARNING!</p> <p>The inverter is equipped with RS485, USB, SNMP card, but only one at the same time.</p>
---	---

6 Operation

6.1 Control Panel

The display is operated by four buttons.

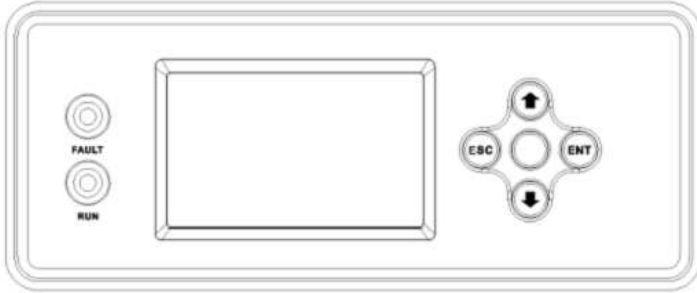

6.2 Button Description

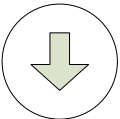
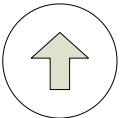
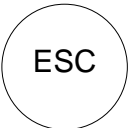
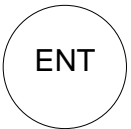
Symbol	Name	Function
	Down	Press and hold for 0.5 s to select menu or number
	Up	Press and hold for 0.5 s to select menu or number
	Escape button	Press this button to go back, press this button in main interface to mute audible alarm.
	Enter button	Press this button to confirm the operation

6.3 LED Indicator



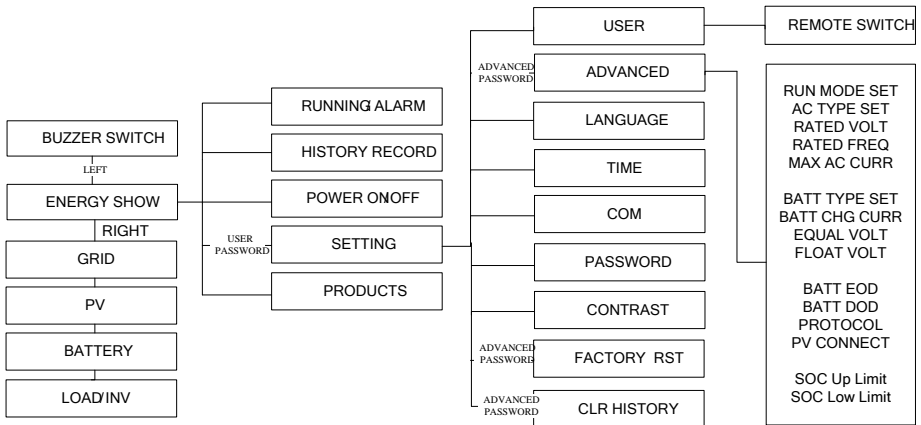

LED Indicator	Status	Function description	Buzzer
FAULT (red)	Red on	Major: It displays the relevant fault and the inverter is shut down.	Once /1 second warning
	Once/1second flash	Minor: It displays the relevant fault and the inverter still can operate.	Mute
RUN (green)	Green on	Normal working: The inverter is in normal operating status.	Mute

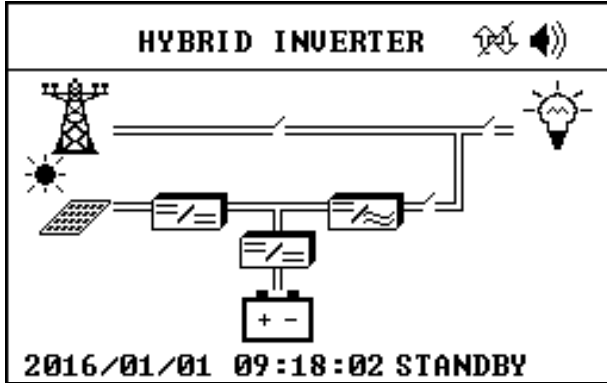

6.4 LCD Menu structures





This is the default interface, and the LCD will automatically skip to this interface when the system start up successfully or not operate the buttons for a period of time.

Press “↑, ↓” buttons to select , , ,  icon, press “ENT” to view the relevant information via “grid, battery, output, PV”.

Grid	SOC SETTING																					
<table border="1"> <thead> <tr> <th colspan="2">GRID INFO.</th> </tr> </thead> <tbody> <tr> <td>VOLTAGE <U></td> <td>: 0.0</td> </tr> <tr> <td>FREQUENCY<Hz></td> <td>: 0.00</td> </tr> <tr> <td>ACTIVE <W></td> <td>: 0</td> </tr> <tr> <td>APPARENT <VA></td> <td>: 0</td> </tr> <tr> <td>STATUS</td> <td>: N/A</td> </tr> </tbody> </table>	GRID INFO.		VOLTAGE <U>	: 0.0	FREQUENCY<Hz>	: 0.00	ACTIVE <W>	: 0	APPARENT <VA>	: 0	STATUS	: N/A	<table border="1"> <thead> <tr> <th colspan="2">ADVANCED SET</th> <th>P4/4</th> </tr> </thead> <tbody> <tr> <td> SOC Up Limit</td> <td>: 50</td> <td>%</td> </tr> <tr> <td>SOC Low Limit</td> <td>: 5</td> <td>%</td> </tr> </tbody> </table>	ADVANCED SET		P4/4	 SOC Up Limit	: 50	%	SOC Low Limit	: 5	%
GRID INFO.																						
VOLTAGE <U>	: 0.0																					
FREQUENCY<Hz>	: 0.00																					
ACTIVE <W>	: 0																					
APPARENT <VA>	: 0																					
STATUS	: N/A																					
ADVANCED SET		P4/4																				
 SOC Up Limit	: 50	%																				
SOC Low Limit	: 5	%																				

Load	Output																								
<table border="1"> <thead> <tr> <th>LOAD INFO.</th> <th>P1/2</th> </tr> </thead> <tbody> <tr> <td>VOLTAGE <U></td> <td>: 0.0</td> </tr> <tr> <td>CURRENT <A></td> <td>: 0.0</td> </tr> <tr> <td>APPARENT <VA></td> <td>: 0</td> </tr> <tr> <td>ACTIVE <W></td> <td>: 0</td> </tr> <tr> <td>PERCENT <%></td> <td>: 0.0</td> </tr> </tbody> </table>	LOAD INFO.	P1/2	VOLTAGE <U>	: 0.0	CURRENT <A>	: 0.0	APPARENT <VA>	: 0	ACTIVE <W>	: 0	PERCENT <%>	: 0.0	<table border="1"> <thead> <tr> <th>INU INFO.</th> <th>P2/2</th> </tr> </thead> <tbody> <tr> <td>VOLTAGE <U></td> <td>: 0.0</td> </tr> <tr> <td>CURRENT <A></td> <td>: 0.0</td> </tr> <tr> <td>FREQUENCY<Hz></td> <td>: 0.00</td> </tr> <tr> <td>ACTIVE <W></td> <td>: 0</td> </tr> <tr> <td>STATUS</td> <td>: N/A</td> </tr> </tbody> </table>	INU INFO.	P2/2	VOLTAGE <U>	: 0.0	CURRENT <A>	: 0.0	FREQUENCY<Hz>	: 0.00	ACTIVE <W>	: 0	STATUS	: N/A
LOAD INFO.	P1/2																								
VOLTAGE <U>	: 0.0																								
CURRENT <A>	: 0.0																								
APPARENT <VA>	: 0																								
ACTIVE <W>	: 0																								
PERCENT <%>	: 0.0																								
INU INFO.	P2/2																								
VOLTAGE <U>	: 0.0																								
CURRENT <A>	: 0.0																								
FREQUENCY<Hz>	: 0.00																								
ACTIVE <W>	: 0																								
STATUS	: N/A																								
PV	NEW VER																								

PU INFO. BUS VOLT(U) : 0.0 PU VOLT(U) : 0.0 CURRENT (A) : 0.0 POWER (W) : 0	BATTERY INFO. VOLTAGE (V) : 45.6 CURRENT (A) : 0.0 SRATUS : NONE SOC (%) : 23
--	--

6.5 System Information Inquiry

MENU
 RUNNING INFO. HISTORY RECORD POWER ON / OFF SYSTEM SET PRODUCT INFO.

In the standby interface, press “ENT” button to enter the main menu, press “↑, ↓” to select related items to view. Moreover, press “ENT” to confirm. The “RUNNING INFO.” shows the running conditions such as grid power, load power, as below.

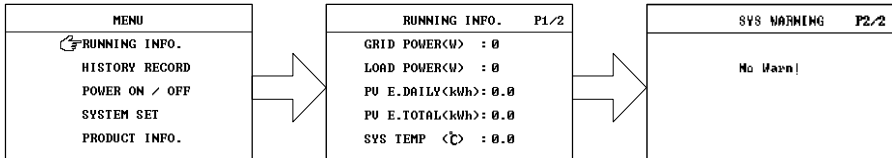

Display	Description
GRID POWER(W)	Grid input power “+” indicates feeding power back into the Grid; “-” indicates getting power from the grid
LOAD POWER(W)	System present load power
PV E. DAILY(KWH)	PV Daily generated power
PV E. TOTAL(KWH)	PV Total generated power
SYS TEMP(°C)	Inside temperature
SYS WARNING	Fault and alarm records

Note: For 3.6 KW, GRID POWER indicates the input and output power from the inverter grid port. LOAD POWER indicates power of backup load.

6.6 Factory Information Inquiry

Press "ENT." to enter "Main menu", use "↑, ↓" to select "PRODUCT INFO.", press "ENT." to confirm; press "ESC" to return to main menu interface.

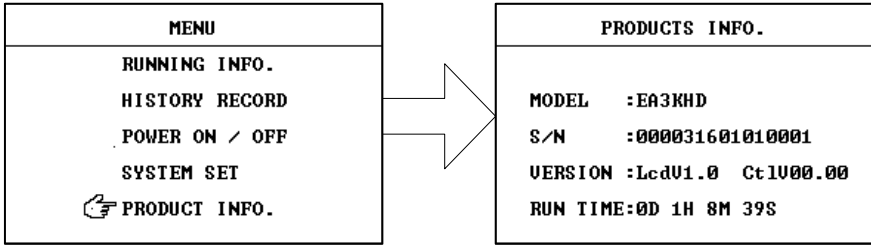

6.7 Switching On and Off

➤ Press "ENT" button, then press "↑, ↓" to enter main menu to select "power on/off", then press "ENT." button for execution:

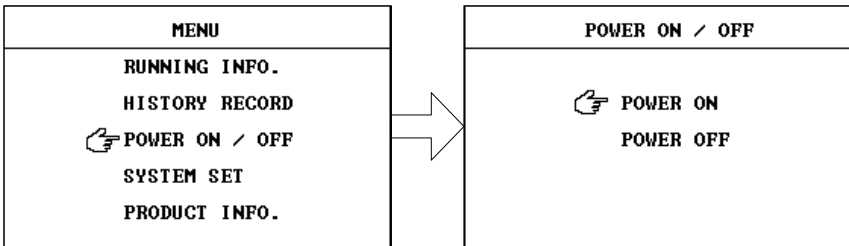

Note: In normal condition, the system will perform startup and shutdown according to the AC input and battery status.

- Maintenance method for not using for a long time:
 - If the inverter is not used for more than 7 days, switch off the AC input, PV input and battery input breaker.
 - If the inverter is not used for more than 3 months, switch on the AC input breaker (or PV breaker), and start the system to charge the battery.

6.8 Self-test

In the default interface, press "ENT" button to go to the main menu, then press "↑, ↓" to select "POWER ON/OFF", press "ENT" to confirm, use "↑, ↓" to select "AUTOTEST", press "ENT" to enter the user password (the default password is "000000") to go to the auto test set interface.

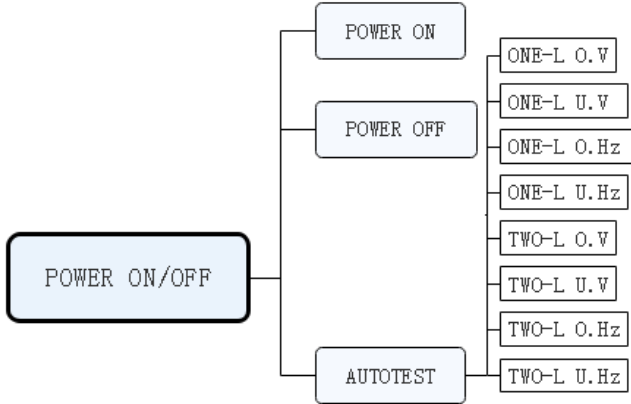
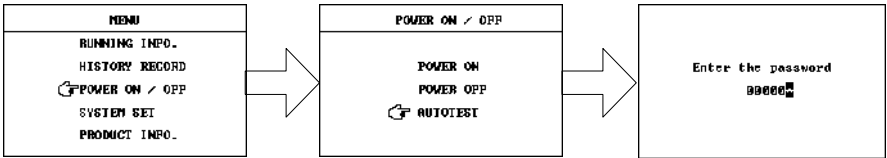

Press "ENT" to start the selection, use "↑, ↓" to select the parameter for auto test, press "ENT" to confirm your selection. The self-test function allows you to test the following items: "one-level undervoltage", "one-level overfrequency", "one-level underfrequency", "two-level overvoltage", "two-level undervoltage", "two-level overfrequency", "two-level underfrequency".



During the test, the threshold of selected parameter changed with a ramp ratio ≤ 0.05 Hz/s or 0.05 Vn/s to the rated value until the coincidence between the threshold and current measured value. After that, the inverter sends a tripping signal to the tripping device according to the setting. A report will be displayed on the screen as the self-test is finished. The parameters of the report are listed below:

- Threshold setting value: The value set in the SPI
- Threshold setting trip time: The trip time set in the SPI
- Threshold auto test value: Threshold when the threshold is consistent with the current measurement
- Threshold auto test trip time: The time from the coincidence between the threshold and current to the trip signal of disconnection switch
- Current measured voltage or frequency value: The threshold value and the current measured value is correspond to the measured value of the grid voltage or frequency

If the automatic test is not successful, the inverter will automatically disconnect from the grid.

- Voltage threshold $\leq 1\%$
- ± 20 mHz for frequency thresholds
- Trip time $\leq 3\% \pm 20$ ms

Notice:

The self-test function can be run only when the grid is connected and the inverter is turned on.

It will be turned off automatically after self test, which is normal. It will be turned on automatically a few minutes after pursuing “ESC”.

Do not perform other operations during the self-test.

There may not be self-test function for the versions in some countries.

7 Settings

In the main interface, press “ENT” button to enter “Main Menu”; press “↑, ↓” to select “SYSTEM SET” and press “ENT” to enter the password (the system default password is “000000”) press “ENT” to enter the “SYSTEM SET.”



7.1 User Settings

In the “SYSTEM SET” interface, press “↑, ↓” to select the “USER SET ” item, press “ENT” and then press “↑, ↓” to select the REMOTE SET, press “ENT” to confirm. At last press “ESC” to return.

SYSTEM SET	
☞ USER SET	PASSWORD SET
ADVANCED SET	CONTRAST SET
LANGUAGE	FACTORY RST
TIME SET	CLR HISTORY
COM SET	TIMER SWITCH

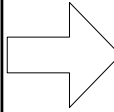

USER SET	
☞ REMOTE SET	: ON
DAILY KWH	: 000000
TOTAL KWH	: 000000

7.2 Advanced Settings

In the “SYSTEM SET” interface, press the “↑, ↓” keys to select “ADVANCED SET” option, press the “ENT” to confirm; press “ENT” to enter the password (if need to change this setting, contact the dealer), press “↑, ↓” keys to select the number, press “ENT” to confirm. In SYSTEM SET item, press “↑, ↓” key to select sub-item, press “ENT” to select; press “↑, ↓” to modify or select, Press “ESC” to return the system settings.

SYSTEM SET	
USER SET	PASSWORD SET
☞ ADVANCED SET	CONTRAST SET
LANGUAGE	FACTORY RST
TIME SET	CLR HISTORY
COM SET	TIMER SWITCH



Enter the password
 █*█*█*█*

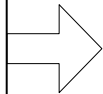

ADVANCED SET	P1/4
☞ RUN MODE SET	: GRID-TIED
AC TYPE SET	: GRID
RATE VOLT	: 220V
RATE FREQ	: 50Hz
MAX AC CURR	: 10A



ADVANCED SET	P2/4
☞ MAX GRID VOLT	: 276V
MIN GRID VOLT	: 176V
MAX GRID FREQ	: 52.0Hz
MIN GRID FREQ	: 47.5Hz

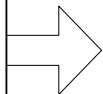

ADVANCED SET	P3/4
☞ BATT TYPE SET	: LEAD
BATT NUM SET	: 1
MAX CHG CURR	: 25A
EQUAL VOLT	: 57V
FLOAT VOLT	: 54V



ADVANCED SET	P4/4
EOD OFF GRID	: 42V
☞ FOD OFF GRID	: 45V
EOD ON GRID	: 42V
DOD ON GRID	: 45V

The default operation mode of the inverter is “grid-connected mode”. User can set the working mode as “grid-connected mode” or “anti-reflux mode”.

- Anti-reflux: the system is in anti-reflux operation mode, however, it does not sell electricity to the grid;

- Grid-connected feeding: when the power grid is available for the system, the electricity can be sold to the grid;
- Lead-acid batteries or lithium batteries are available;
- The shutdown mode EOD battery is defaulted as 42V;
- DOD is battery discharge end voltage, which is defaulted as 45V;
- Rated voltage: Rated voltage of the inverter output can be set as 220V / 230V / 240V. The system will automatically recover to the previous setting when it is set to other value except these three voltage values;
- Rated frequency: Rated frequency of the inverter output can be set as 50Hz / 60Hz. The actual output frequency depends on the local grid. The system will automatically recover to the previous setting when it is set to other value except these two frequency values;

	WARNING!
	<ul style="list-style-type: none"> • After the advanced settings is completed, the inverter must be powered off and restarted, or the invert will not operate according to the settings. • Improper setting can result in violation of local electrical regulations and may result in unnecessary financial loss to the user. If it needs adjustment, it must be authorized by a qualified technician or contact your local dealer.

7.3 Language

In the “SYSTEM SET” interface, press “↑, ↓” to select the “LANGUAGE ” item, press “ENT” and then press “↑, ↓” to select the language (Chinese & English), press “ENT” to confirm. At last press “ESC” to return.

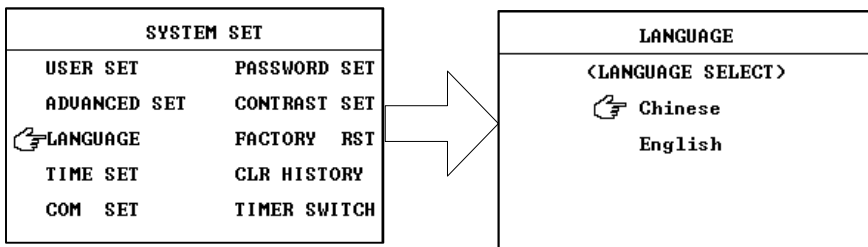

7.4 TIME Settings

This interface is for user to set the system date and time. In the “SYSTEM SET” interface, press “↑, ↓” to select “TIME SET”, then press “ENT” to confirm; press “↑, ↓” to modify the number, press “ENT” to confirm; Press “ESC” to exit from setting.

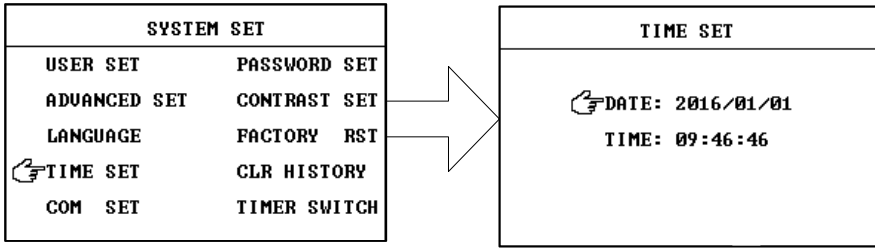

7.5 Communication Settings

In the “SYSTEM SET” interface, press the “↑, ↓” keys to select “COM SET” option, press the “ENT” to confirm; press “↑, ↓” keys to modify, press “ENT” to confirm; press “ESC” to exit.

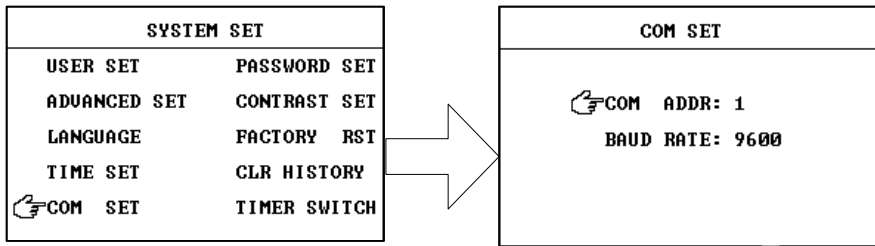

	WARNING!
<p>Incorrect settings will result in the abnormality of device communication and monitoring. This setting must be performed by qualified technicians. The default should be set to 2400.</p>	

7.6 Password Settings

This interface is for user to set the new password. In the “SYSTEM SET” interface, press “↑, ↓” keys to select “Password SET” option, press the “ENT.” To confirm; press “↑, ↓” keys to modify values, press “ENT” to confirm; Press “ESC” to return to the system settings interface.

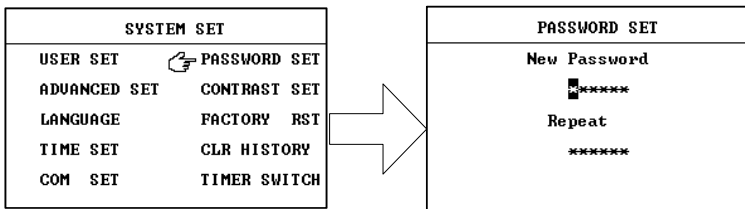

7.7 Contrast Settings

In the “SYSTEM SET” interface, select “CONTRAST SET”, press “ENT” to enter the contrast setting interface, press “↑, ↓” to modify the values; press “ENT” to confirm; press “ESC” to return system setting interface.

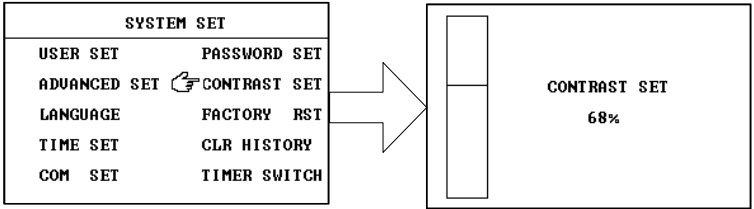

7.8 Factory Reset

This interface is for user to restore factory settings. After restoring factory settings is complete, all parameters except the current date and time will restore the default factory settings. However, the operating information, alarm records and system logs will not be cleared or modified.

In the “SYSTEM SET” interface, select “FACTORY RST”, press “ENT.” and enter the correct password to “FACTORY RESET” interface, press the “↓, ↑” keys to select “Yes” or “No”; press “ENT.” to confirm; press “ESC” to return system setting interface.



	WARNING!
	<ul style="list-style-type: none"> ➤ After completing factory reset settings, the inverter must be powered off and restarted, otherwise may result in abnormality of the inverter. ➤ If it is not necessary, do not perform this setting rashly. If necessary, contact the technical staff.

7.9 Timer Switch (3KW only)

In the “SYSTEM SET” interface, select “TIMER SWITCH,” press “ENT” to enter setting interface and select the corresponding time. Press “ENT” to complete the setting.

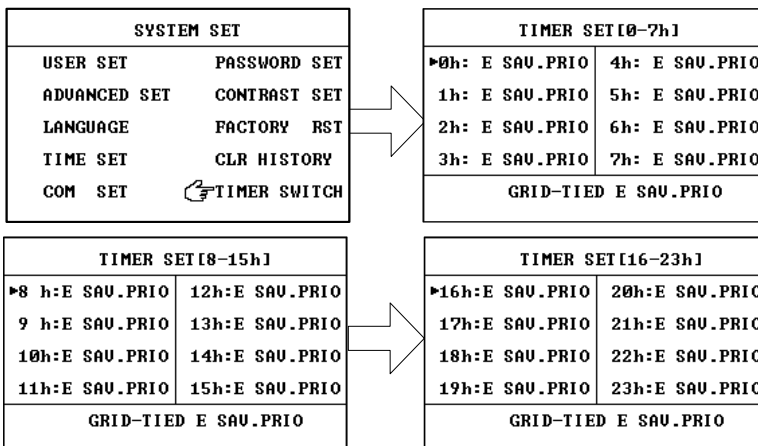

The time of TIMER SET is based on the system time of the inverter. The period of time 0h shows time from 0:00 to 0:59, 1h shows time from 1:00 to 1:59, the meaning of other periods of time is similar as this. Each period of time has three operating modes: E SAV.PRIO, E GEN.PRIO, AC CHA.OFF.

AC CHA.OFF: The grid does not charge the battery.

E SAV.PRIO: Energy storage priority mode.

E GEN.PRIO: Power supply priority.

Refer to chapter 8 Operation Mode for details.

Note: Timer Switch function is only suitable for standard models.

8 Work Mode

8.1 3KW Work Mode

GRID-TIED Mode	
E GEN.PRIO I	PV energy priority for load, excess energy is delivered to the Grid, what finally remaining is used to charge the battery.
	when PV energy isn't sufficient, the insufficient part is supplemented by the battery. the energy priority for load, Other to the Grid.
	The Grid does not provide energy to the battery.
E SAV.PRIO I	PV energy priority for charging the battery, excess energy is used to load, what finally remaining is delivered to the Grid.
	When PV energy isn't sufficient for load, the insufficient part is supplemented by the Grid.
	When PV energy isn't sufficient for charging, the insufficient part is supplemented by the Grid, load are powered by the Grid.
AC CHA.OFF I	PV energy priority for charging the battery, excess energy is used to load, what finally remaining is delivered to the Grid.
	When PV energy isn't sufficient for load, the insufficient part is

	supplemented by the Grid.
	When PV energy isn't sufficient for charging, the GRID powers the load, but it does not supplement charge
ANTI-TIED Mode	
E GEN.PRIO II	PV energy priority for load, excess energy is used to charge the battery, no energy to the Grid.
	when PV energy isn't sufficient, the insufficient part is supplemented by the battery. no energy to the Grid.
	The Grid does not provide energy to the battery.
E SAV.PRIO II	PV energy priority for the battery, excess energy is for loads, no energy to the Grid.
	When PV energy isn't sufficient for load, the insufficient part is supplemented by the Grid.
	When PV energy isn't sufficient for charging, the insufficient part is supplemented by the Grid, load are powered by the Grid.
AC CHA.OFF II	PV energy priority for the battery, excess energy is for loads. no energy to the Grid.
	When PV energy isn't sufficient for load, the insufficient part is supplemented by the Grid.
	When PV energy isn't sufficient for charging, the GRID powers the load, but it does not supplement charge
Bypass Mode	
---	When PV and battery are disconnected, the Grid directly supply power to the load by the relay
Off Grid Mode	
---	PV energy priority for load, excess energy is used to charge the battery.
	when PV energy isn't sufficient, the insufficient part is supplemented by the battery.

Note:

- 1 The Operating status of inverter will be adjusted automatically according to the state of the power grid, PV and the battery. But the operation mode (ANTI-TIED or GRID-TIED Mode) need to be set manually.
- 2 GRID-TIED Mode, E GEN.PRIO I : When the battery voltage is lower than the DOD ON GRID, the power of the inverter is automatically reduced to keep the battery voltage above the DOD ON GRID.
- 3 Off Grid Mode, The battery voltage below DOD will warn "BATT UNDER VOLT" in the discharge. The battery voltage discharges below EOD, inverter will shutdown discharge function. At this time, the PV access inverter will enter the mandatory charging mode. In this mode, the inverter will only charge the battery until the float charge, and the inverter will return to normal working mode.

8.2 3.6KW Work Mode

GRID-TIED Mode	
PV + Grid	PV energy priority for backup loads, excess energy for house loads, what finally remaining is delivered to the Grid.
	When PV energy isn't sufficient, the insufficient part is supplemented by the Grid.
Battery + Grid	Battery energy priority for backup loads, excess energy for house loads, and will not sell electricity to the grid
	When the battery voltage is lower than DOD, the battery will not be discharged, loads are powered by the Grid.
	Battery will not be charged by the Grid.
PV + battery + Grid	The transformation of PV power will follow this working priority Backup loads > battery charging > house loads > to the Grid
	When house loads are bigger respect the PV power, the extra energy will be bought from the Grid
	When backup loads are bigger respect the PV power, the insufficient energy will be supplied by the battery, the house loads are powered by the Grid.
ANTI-TIED Mode	
	The difference between ANTI-TIED and GRID-TIED is that energy will not be delivered to the Grid. in ANTI-TIED Mode.
Off-Grid Mode	
PV powered	Backup loads are powered by PV.
Battery powered	Backup loads are powered by battery.
PV + battery	PV energy priority for backup loads, excess energy is for battery charging,
Bypass Mode	
	When PV and battery are disconnected, the Grid directly supply power to the load via the relay

Note:

- 1 The Operating status of inverter will be adjusted automatically according to the state of the power grid, PV and the battery. But the operation mode (ANTI-TIED or GRID-TIED mode) need to be set manually.
2. GRID-TIED Mode :The battery voltage discharges below Grid on DOD, the battery will stop discharging and the load is supplied by the grid. Until the PV access and charging into the 57V "are charging" stage will not have to re-discharge capacity. After the battery voltage is lower than the grid DOD point, the grid disappears, and the battery discharge will be restarted to ensure the backup load to run.
3. Off-Grid Mode: The battery voltage below Grid off DOD will warn "BATT UNDER VOLT" in the discharge. The battery voltage below Grid off EOD , inverter will

shutdown discharge function. At this time, the PV access inverter will enter the mandatory charging mode. In this mode, the inverter will only charge the battery until the float charge, and the inverter will return to normal working mode. During the mandatory charging mode, Grid access will end the mandatory charging and re-discharge capacity.

4. "Grid-Tied" means the energy transfer from the "AC input" interface of the inverter.
5. The "ANTI- TIED" of the standard model uses AC INPUT interface as the demarcation point of selling & buying electricity; the inverter with digital meter or CT uses digital meter or CT as the demarcation point of selling & buying electricity.



9 Maintenance

9.1 Preventive Maintenance

To ensure the reliability and long service for the inverter system, do following checking each month:

- Shut down the inverter, disconnect the switches on input and output sides;
- Ensure that the ventilation holes are not blocked;
- Check if there is too much dust on the cover;
- Ensure the products are not damp;
- Close the switches on input and output sides and turn on the inverter.

9.2 Battery maintenance

	<p>WARNING!</p>
	<p>Servicing of batteries should be performed or supervised by personnel knowledgeable about batteries and the required precautions.</p>
	<p>WARNING!</p>
	<ul style="list-style-type: none"> ➤ A battery can present a risk of electrical shock and high short-circuit current. ➤ Do not dispose of batteries in a fire. The batteries may explode. ➤ Do not open or mutilate batteries. Released electrolyte is harmful to the skin and eyes, and may be toxic.

Battery safety

- Before installing or replacing the batteries, remove all jewelry from hands such as wristwatches and rings. High short circuit current through conductive materials could cause severe burns.
- Wear safety goggles and plastic gloves.

- Work away from open flames and no smoking, hydrogen gas.
- Determine if battery is inadvertently grounded. If inadvertently grounded, remove source from ground.

Environmental factors affect battery life. Elevated ambient temperatures, poor quality utility power, and frequent short duration discharges will shorten battery life. Battery maintenance is an important issue. Follow the simple check below every month:

- The battery should be clean. Clean terminals and connectors as necessary.
- Cable connection needs to be clean and tightened.
- Don't mix size and types of batteries. Be sure to replace the correct same type of battery.

10 Troubleshooting

10.1 History Records

In the Main Menu, press “↓, ↑” to select “HISTORY RECORD” and view historical record; press “ESC” to return to main menu interface.

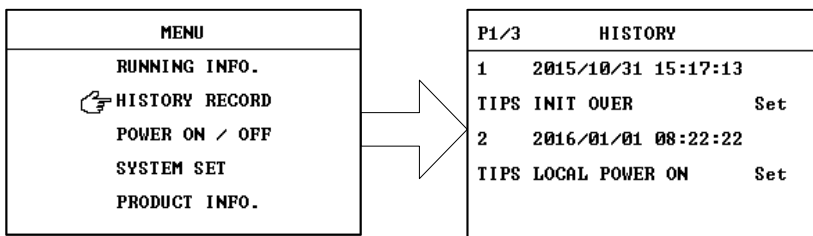

P1/3:P1 is the current number of pages, 3 refers to the total page number of historical records;

1 refers to the first historical record, 2015/10/31 means the date that history occurred.

15: 17: 13 refers to a specific time that history occurred.

10.2 Clear History Records

In the “SYSTEM SET” interface, select “Clear history record”, press “ENT.” and enter the correct password to enter “Clear history” interface, use the “↓, ↑” to select “YES” or “NO”; press “ESC” to return to system setting interface.



10.3 Fault List

The users can remove faults and take the corresponding measures according to the fault prompts of the inverter. The inverter mainly has the following three kinds of common faults:

Major: LCD displays the current specific faults, red LED indicator keeps on, green LED indicator is off, buzzer begins to emit an alarm, it will be automatically muted after the fault disappears, and it can be muted manually. The inverter is turned off, and it will automatically restart after the fault is disappeared.

Minor: LCD displays the current specific faults, red LED indicator flashes, green LED indicator is off, and the buzzer is mute. The inverter can operate, the corresponding alarm will disappear after the fault disappears.

Warning: LCD displays the current specific faults, red LED indicator is off, green LED indicator keeps on, and the buzzer is mute. The inverter operates normally.

Common alarm information and solutions:

Problem	Possible cause	Corrective Action
NO BATT	1.The battery is not connected properly. 2.Battery fuse blown.	If batteries are connected: 1. Check if battery cable is connected firmly. 2. If error message remains, please contact your installer.
NO PV	1.PV connection is not correct. 2.PV voltage is too low.	If PV are connected: 1. Check if PV cable is connected firmly. 2. If error message remains, please contact your installer.
BATT UNDER VOLT	1.Battery voltage is abnormal.	1. Check if the connection between battery and inverter and the battery voltage is normally. 2. The battery line is too thin. 3. Restart the inverter, if error message remains, please contact your installer.
BATT OVER VOLT	2.The battery is fully discharged.	
NO GRID	1.The grid is not connected properly. 2.Mains fuse blown.	If Grid are connected: 1. Check if Grid cable is connected firmly. 2. If error message remains, please contact your installer.
PV SHORTAGE	The PV power is too low to initiate the inverter.	The inverter detects its external working conditions in real time, and therefore the inverter automatically recovers to the normal operating status after PV power reach enough to initiate the inverter.
PV OVER VOLT	Photovoltaic open circuit voltage is too high.	Check whether the large number of PV modules connected in series make the open circuit voltage of the PV arrays greater than the maximum input voltage of the inverter. If yes, adjust the number of PV arrays connected in series to decrease the output voltage of PV arrays to meet the voltage requirements for the inverter. If

		no, contact your installer. After the adjustment, ensure that the inverter works properly.
PV REVERSE	The cables between PV arrays are connected reversely during inverter installation.	Check whether the cables between PV arrays and the inverter are connected reversely. If they are connected reversely, reconnect the cables properly.
BUS UNDER VOLT	The inverter input is suddenly disconnected, or the PV array to be obstructed result in a sharp change in output power.	<ol style="list-style-type: none"> 1. The inverter detects its external working conditions in real time, and therefore the inverter automatically recovers to the normal operating status after the fault is rectified. 2. If the alarm occurs repeatedly, contact your installer.
BUS OVER VOLT	The sharp change of Grid voltage cause inverter input energy short period of time can not be vented so that the internal voltage increases.	<ol style="list-style-type: none"> 1. The inverter detects its external working conditions in real time, and therefore the inverter automatically recovers to the normal operating status after the fault is rectified. 2. If the alarm occurs repeatedly, contact your installer.
INV OVER VOLT	The output voltage of the inverter is beyond the acceptable range.	<ol style="list-style-type: none"> 1. The inverter detects its external working conditions in real time, and therefore the inverter automatically recovers to the normal operating status after the fault is rectified. 2. If the alarm occurs repeatedly, contact your installer.
INV UNDER VOLT		
ISLAND	Islanding condition is detected.	<ol style="list-style-type: none"> 1. Check whether AC circuit breaker is triggered and whether AC cables are all firmly connected. 2. Check whether Grid is not in service. 3. If all conditions are OK and this fault still occurs in the LCD screen, contact your installer.
GRID OVER VOLT	The inverter will turn to Off-Grid mode, the inverter automatically recovers to the normal operating status after the fault is rectified.	<ol style="list-style-type: none"> 1. Check the voltage or frequency of the Grid. 2. If the Grid voltage or frequency exceeds the permissible range of inverter protection parameters, ask utility Grid company for solution. 3. If the Grid voltage or frequency is within the permissible range, contact your installer.
GRID UNDER VOLT		
GRID OVER FREQ		
GRID UNDER FREQ		
BUS HARD OVER VOLT		
BUS UNDER VOLT	Abnormal external conditions trigger the protection for the DC circuit inside the inverter.	<ol style="list-style-type: none"> 1. The inverter detects its external working conditions in real time, and therefore the inverter automatically recovers to the normal operating status after the fault is rectified. 2. If the alarm occurs repeatedly, contact your installer.
BUS OVER VOLT		
GRID DC OVER CURR	The DC component of AC current exceeds inverter limit.	<ol style="list-style-type: none"> 1. Wait a moment for inverter recovery. 2. If the fault occurs repeatedly, contact your installer.
INV DC OVER CURR		
BATT OVER CURR	Inappropriate battery	<ol style="list-style-type: none"> 1. Check whether battery voltage exceeds the

BATT CHG HARD OVER CURR	specifications are used.	permissible range of inverter. 2. If the fault occurs repeatedly, contact your installer.
DISCHG HARD OVER CURR		
GRID RELAY FAULT	Relay fault is detected.	1. Power off and restart the inverter. 2. If the fault occurs repeatedly, contact your installer.
INV RELAY FAULT		
LOAD RELAY FAULT		
BUS SOFT START FAIL	1. Bust voltage soft-start is time-out. 2. Battery capacity is too low.	1. Wait a moment for inverter recovery. 2. Charge the battery. 3. If the error message still remains, please contact your installer.
INV SOFT START FAIL	Battery Inverter output soft-start is time-out.	
INV LOCK PHASE FAULT	Phase Locked Loop fault.	1. Turn off the inverter. 2. Then restart the inverter. 3. If the error message still remains, please contact your installer.
EEPROM ERROR	EEPROM fault is detected.	1. Turn off the inverter. 2. Then restart the inverter. 3. If the error message still remains, please contact your installer.
BOOST1 HARD OVER CURR	Boost1 over current is detected.	1. Wait a moment for inverter recovery. 2. If the fault occurs repeatedly, contact your installer.
BOOST1 SOFT OVER CURR		
LEAKAGE CURRENT	The insulation resistance against the ground at the input side becomes lower in operating mode, which causes excessively high residual current.	1. If the fault occurs accidentally, the possible cause is that the external circuits are abnormal accidentally. The inverter automatically recovers to the normal operating status after the fault is rectified. 2. If the fault occurs repeatedly and lasts a long time, check the insulation resistance against the ground of PC arrays is excessively low.
INV GND OVER CURR		
ISO RES FAULT	The insulation resistance against the ground for PV arrays is less than the minimum value. The possible causes are as follows: 1. The ground cable for the PV arrays is short-circuited. 2. PV arrays are installed in a long-term moist environment.	1. Check the insulation resistance against the ground for the outputs of PV arrays. If a short circuit occurs, rectify the fault. 2. If the insulation resistance against the ground is less than the default value in a rainy environment, set the insulation resistance threshold.
Fan fault	Fan Device Fault.	1. Please check if fans are running ok.

		<ol style="list-style-type: none"> If fans are running ok, please shut down inverter first and then, restart it. If fans are stop running or error message remains after restart the inverter, please contact your installer.
DSP SOURCE FAULT	DSP board power low.	<ol style="list-style-type: none"> Turn off the inverter. Then restart the inverter. If the error message still remains, please contact your installer.
GF OUT SHORT CIRCUIT	Load output short circuit.	<ol style="list-style-type: none"> Turn off the inverter and disconnect all circuit breakers. Check if load output circuit is ok. After removing the error, turn on breaker and the inverter. If error message remains, please contact your installer.
GRID LOAD REVERSE	Reverse connection of AC input and load output wires.	<ol style="list-style-type: none"> Turn off the inverter and disconnect all circuit breakers. Check if AC input wires (Grid wires) are connected to load output terminals. If mis-connected, re-connect it correctly. And turn on circuit breakers and the inverter again. If error message still remains, please contact your installer.
SOFT VER ABNORMA	Version Mismatch.	<ol style="list-style-type: none"> Shut down the inverter completely. Restart the inverter to see if it's ok. If error message still remains, please contact your installer.
ON GRID OVER LOAD 110%	Overload fault.	<ol style="list-style-type: none"> Remove excessive loads. Be sure that total connected loads are less than maximum power consumption this inverter can support. Then, restart the inverter.
ON GRID OVER LOAD 125%		
ON GRID OVER LOAD 150%		
ON GRID OVER LOAD 170%		
RADIATOR OVER TEMP	<ol style="list-style-type: none"> The inverter installation location is not well ventilated. The environment temperature is too high. The internal fan is not working. 	Check whether the operating temperature of the inverter exceeds the upper limit. If yes, improve ventilation to decrease the temperature.
TIPS UPPER COM FAIL	<ol style="list-style-type: none"> The communication address and baud rate are set incorrectly. 	<ol style="list-style-type: none"> Check the communication address and baud rate setting (try to change baud rate to 2400). Check if the communication cable is loose.
TIPS DSP COM FAIL	<ol style="list-style-type: none"> The communication cable is loose. 	<ol style="list-style-type: none"> If error message still remains, please contact your technical staff.

BATT REVERSE	The cables between battery and inverter are connected reversely during the inverter installation.	Disconnect all circuit breakers, check whether the cables between battery are connected reversely. If they are connected reversely, reconnect the cables properly. Contact your installer to check if there is anything damaged.
GRID SHORT CIRCUIT	The inverter AC input cable short-circuit.	<ol style="list-style-type: none"> 1. Check whether the inverter AC input cable is short circuit. 2. If the alarm occurs repeatedly, contact your installer.
INV HARD OVER CURR	Inverter output current is too high.	<ol style="list-style-type: none"> 1. Remove excessive loads. 2. Restart the inverter.
INV SOFT OVER CURR		

11 Appendix

11.1 Terminology paraphrase

ANTI-TIED	It means that the inverter power is prohibited from flowing into the grid, but the grid energy can flow into the inverter, usually using an electric meter or CT as the boundary between the inverter and the grid.
GRID-TIED	Refers to allowing the inverter to send electrical energy to the grid
E GEN.PRIO	It mains inverter supplies power to the load firstly, and charge for the battery secondly .view chapter 8 for details.
E SAV.PRIO	It mains inverter charge for the battery firstly, and supplies power to the load secondly .view chapter 8 for details.
AC CHA.	Refers to allowing the inverter get electric energy from the Grid to charge for the battery.
TIMER.SWITCH	The timer switch says you can set the inverter that which mode to run at a certain period of time.
SOC	State of charge, The state of charge of the battery, also known as the remaining capacity, refers to the ratio of the current available charge of the battery to the charge at full charge, expressed as a percentage, ranging from 0% to 100%.
SOC up limit	refers to the minimum remaining capacity required for the battery discharge to stop discharging due to exceeding the set discharge depth, and then can be discharged again
SOC Low limit	Refers to the maximum depth that allows the battery to discharge. When the remaining capacity of the battery is lower than this value, the battery is not allowed to re-discharge.
BMS	Battery manage system
EOD	End of discharge, In the photovoltaic energy storage products of

	this series, it refers to the voltage point or SOC point that prohibits the battery from discharging. If the battery voltage is lower than this value or the SOC is lower than the lower limit, the inverter will report the “battery under voltage” warning and prohibit the battery from discharging.
DOD	Depth of charge. the voltage of the battery discharge depth, It is a way to show the depth of battery discharge, another way is the SOC
equalizing charge	Refers to the constant current charging phase, in which the charging voltage will gradually increase until the average charging voltage is reached.
EQUAL VOLT	Refers to the target voltage value achieved by constant current charging, which is configurable within the established range.
floating charge	Refers to the constant voltage charging phase, in which the charging current is gradually reduced, maintaining the battery voltage at the set float voltage value.
FLOAT VOLT	Refers to the voltage value of constant voltage charging. This value can be set within the specified range.
House Load	Refers to the load connected between the “AC input ” port of the inverter and the CT/meter accessory. The power of this load is not limited by the inverter (refer to 5.1. System Connection Diagram)
Back Load	Refers to the load connected to the inverter's Load port. When Hybrid invertore off-grid operation, The power of this load is limited by the inverter's load capacity.
EPS	Emergency Power Supply. In Hybrid Inverter series, the silk-screen of the off-grid output port may be "load output" or "EPS". Here, they have the same meaning. they all refer to the "off-grid load" port.

11.2 Running mode (Products series)

Running mode	Hybrid Inverter Mode				
	3KW	3.6KW (Meter Type)	5KW (Meter Type)	3.6KW (CT Type)	5KW (CT Type)
GRID-TIED	Y	Y	Y	Y	Y
ANTI-TIED	Y	Y	Y	Y	Y
E SAV.PROI	Y	N	N	N	N
AC CHA	Y	N	N	N	N
TIMING FUN	Y	N	N	N	N

Note: Y-it has this running mode N-it doesn't have this running mode